

Pneumatic Power Clamps

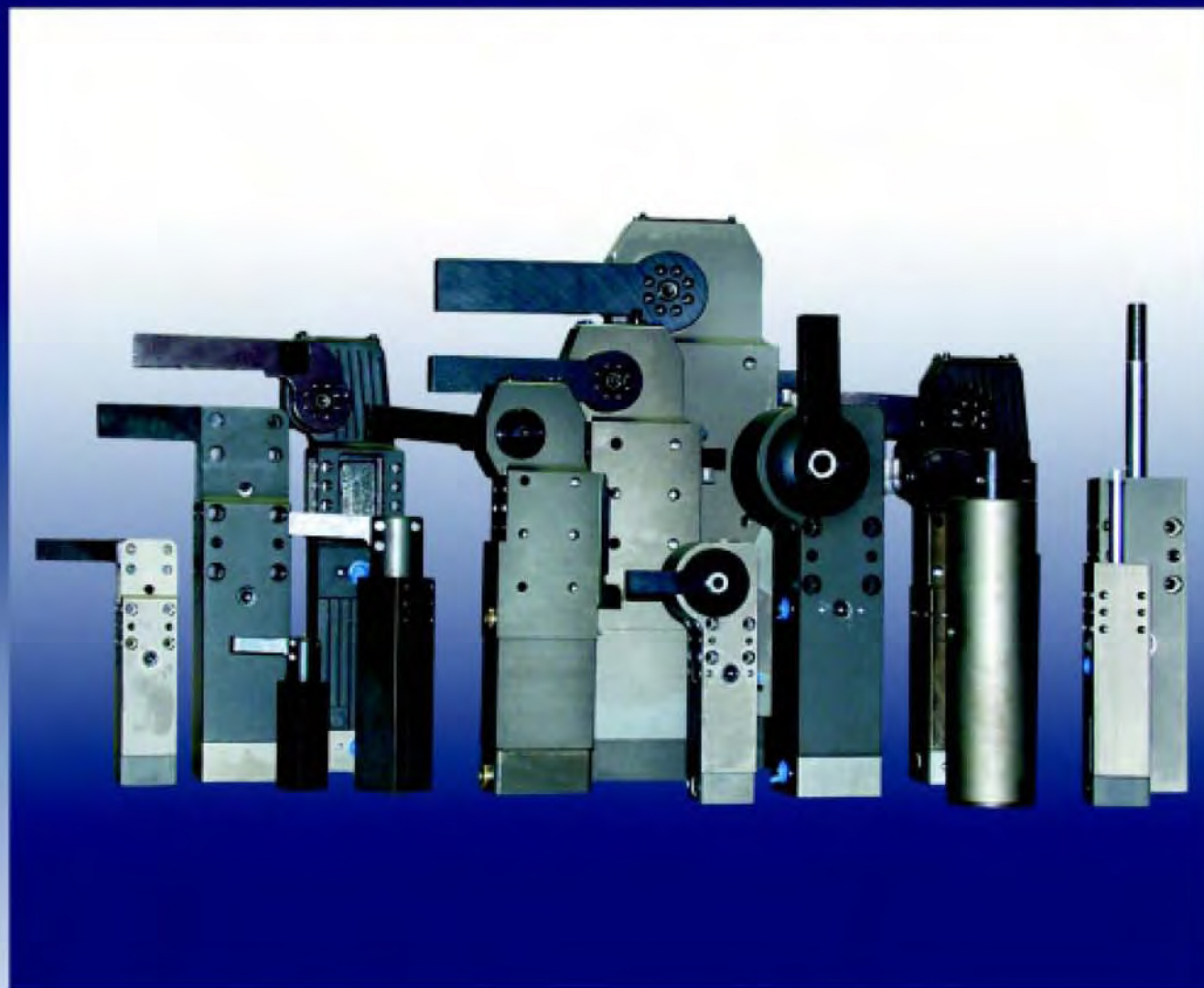

BTM[®]

STANDARD PRODUCTS & AUTOMATION GROUP

CONTENTS

Features.....	Page 4
TRI-LOK description	5
STC 52 Clamp.....	6-7
STC 62 Clamp.....	8-9
STC 82 Clamp.....	10-11
PC 1500 SO Clamp.....	24-25
PC 2500 SO Clamp.....	26
PC 1500 V Clamp.....	27
PC 1500 H Clamp.....	28
PC 1500 PL Clamp.....	29
PC 1500 SL Clamp.....	30
PC 2500 V Clamp.....	31
PC 2500 H Clamp.....	32
PC 2500 PL Clamp.....	33
PC 2500 SL Clamp.....	34



CONTENTS

Omni-Head Clamp description	35
OC 100 V Clamp.....	36
OC 100 H Clamp.....	37
OC 100 SL Clamp.....	38
OC 1500 V Clamp.....	39
OC 1500 H Clamp.....	40
OC 1500 SL Clamp.....	41
RPC 1500 V Clamp.....	42,43
Rotary-Linear Clamp description	44
15-90 CWR / CCR	45
25-90 CWR / CCR	46
Accessories	47

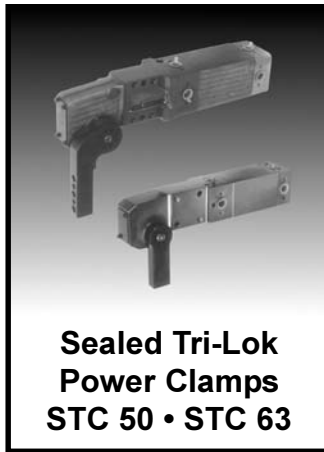



**Sealed Oval Cylinder Tri-Lok
Power Clamps**
STC 52 • STC 62 • STC 82

FEATURES

- Tri-Lok remains locked if air pressure is lost.
- Sealed mechanism ~ Lubricated for life of clamp.
- One piece body ~ Integral cylinder with heavy wall.
- Tri-Lok mechanism ~ Use as a clamp or a precision back-up.
- Hardcoated aircraft aluminum body for excellent wear characteristics.
- Pin arm drive for versatile arm positioning & simplified arm change.
- Integrated proximity switch package or standard proximity switches.
- Adjustable cushions standard on both advance and retract ends.
- Light weight.

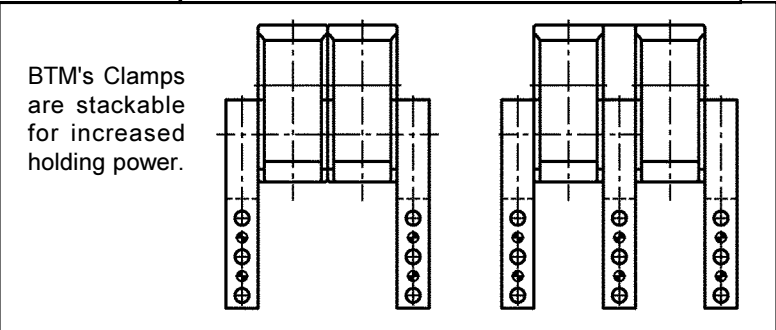
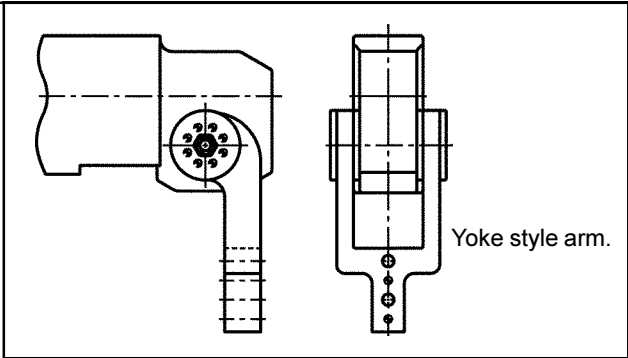
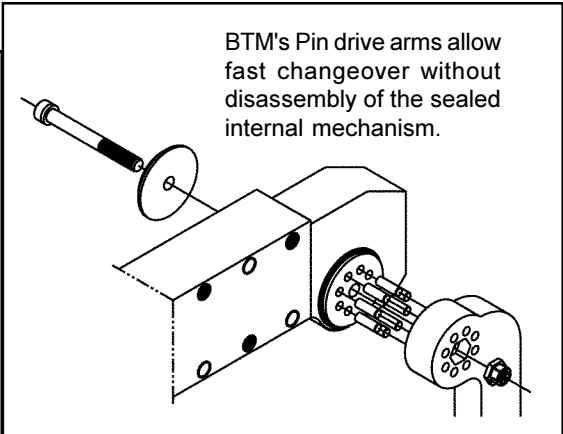
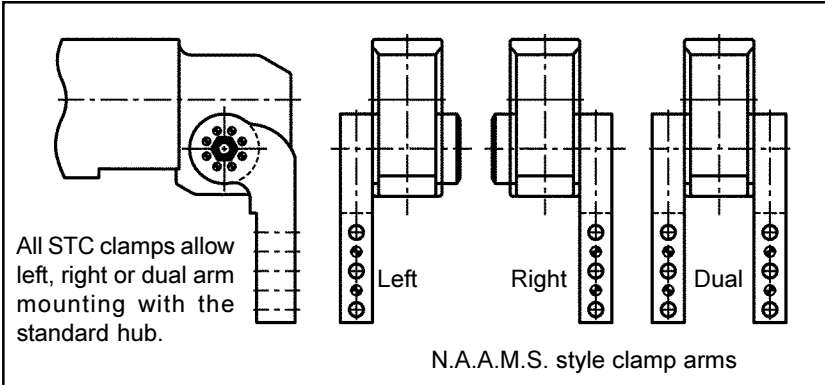

PATENTED & PATENTS APPLIED FOR

TriLok

BTM
CORPORATION

BTM's Tri-Lok mechanism can be used as a clamp or a precision back up and eliminates "over center" clamps

PATENTED & PATENTS APPLIED FOR

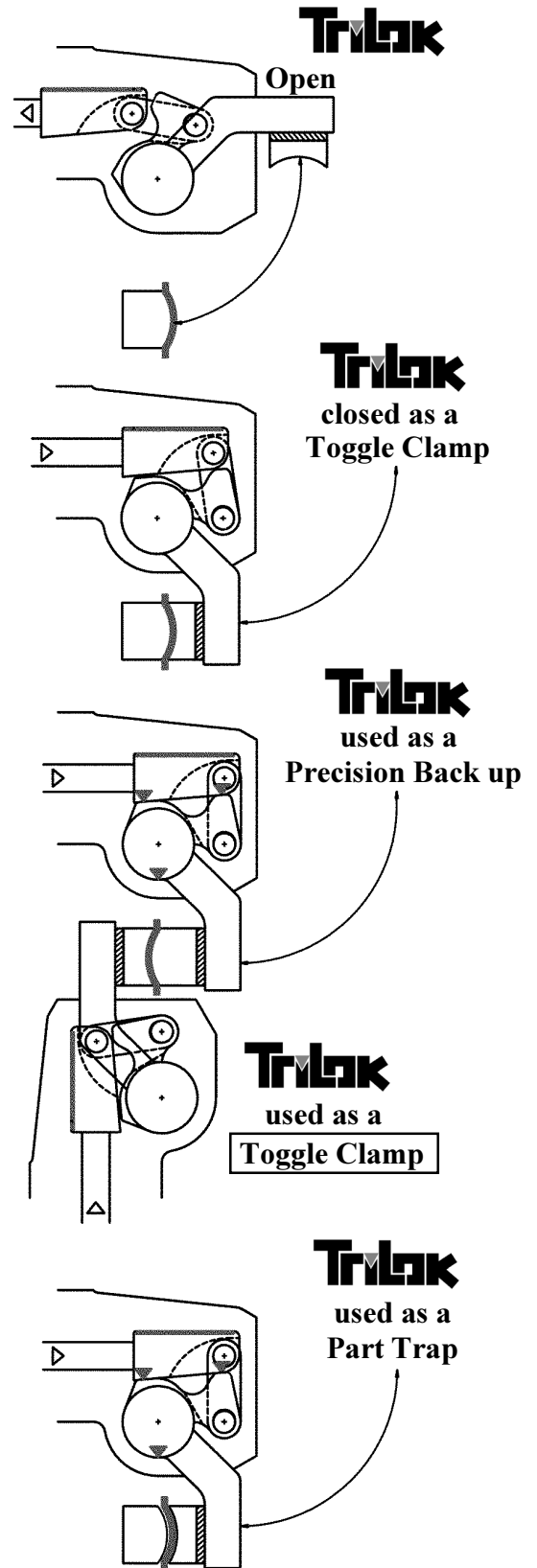
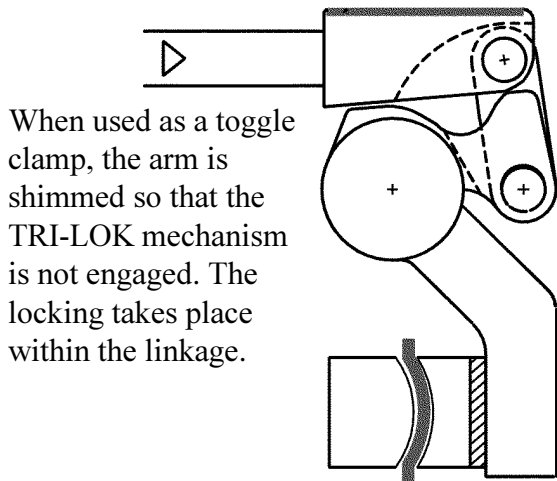
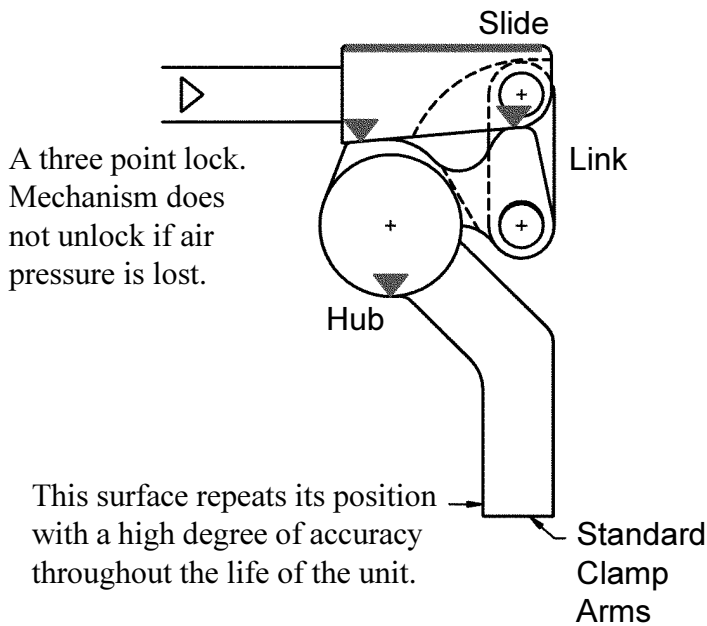

CAD TEMPLATES AVAILABLE
N.A.A.M.S. Preferred

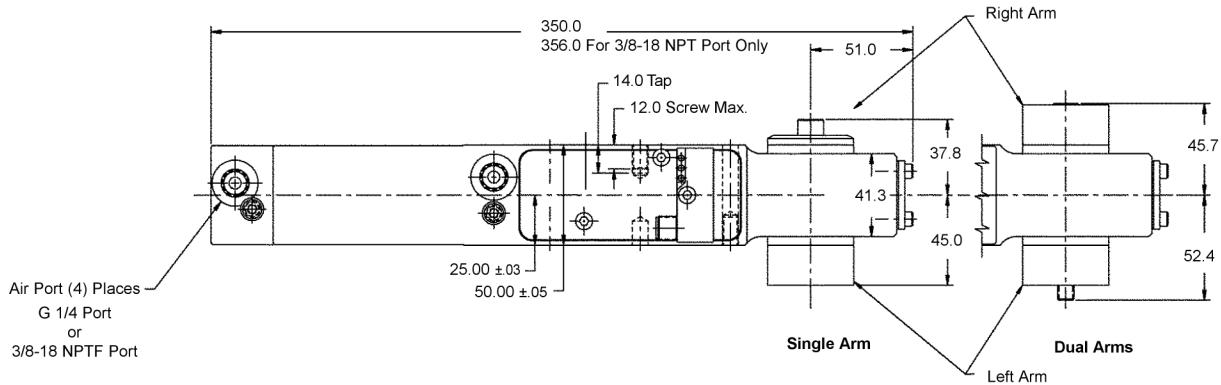

Clamps have a Manual
 Unlock provision for setup.

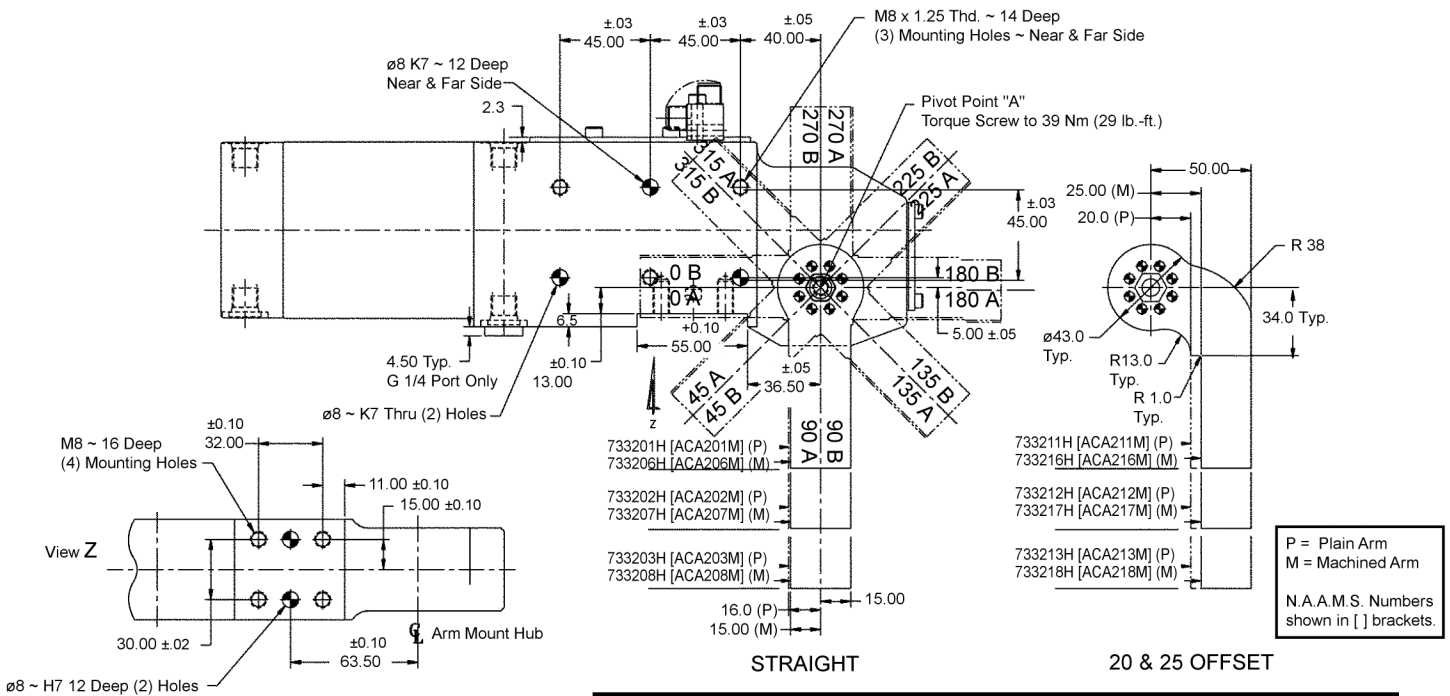

CLAMP ASSEMBLY NUMBERS

ARM OPENING	CYLINDER STROKE	G 1/4 Port		3/8-18 NPTF Port	
		SINGLE ARM	DUAL ARM	SINGLE ARM	DUAL ARM
30°	25.99	733500A	733500J	745000A	745000J
45°	33.17	733500B	733500K	745000B	745000K
60°	40.24	733500C	733500L	745000C	745000L
75°	47.63	733500D	733500M	745000D	745000M
90°	55.40	733500E	733500N	745000E	745000N
105°	63.20	733500F	733500P	745000F	745000P
120°	70.28	733500G	733500R	745000G	745000R

HOW TO ORDER

CLAMP ASSEMBLY NUMBER

ARM STYLE: 733201H THROUGH 733228H

ARM POSITION: 90A, 135A, 180A, 90B, 135B, 180B

ARM LOCATION: L= LEFT SIDE, R= RIGHT SIDE

ARM STYLE: 733201H THROUGH 733228H

ARM POSITION: 90A, 135A, 180A, 90B, 135B, 180B

ARM LOCATION: L= LEFT SIDE, R= RIGHT SIDE

PROX. SWITCH OPTIONS

733200J - 733201H - 90A L - 733201H - 90A R - SC1

LEFT ARM

RIGHT ARM

STC 52 Series Sealed Oval Toggle Clamp ~ Metric Mount

STC52



Standard Switch Package Turck Status Controller DC Ni2-Q6.5-AP6-0.20-FS4.4X3/S304 AC Ni2-Q6.5-ADZ32-0.16-FSB5.4X4/S304 	Switch Package Namco C2000 Sensor DC Type 92 EE280-92140 SC2NDC AC Type 92 EE270-92140 SC2NAC 	Switch Package Pepperl & Fuchs Status Controller DC NBN2-F581-160S6-E8-V1 AC NCN2-F58A1-160S6-U8-V125 	Cylindicator Switch Block SP Switches Not Included Not Available For 30° Opening	Cover Block No Switch NS For Use Without Switches
--	---	---	---	---

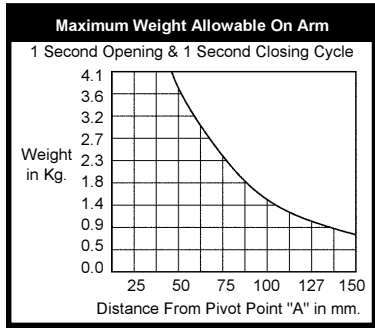

ARM DEFLECTION UNDER LOAD
 Force on arm at "X" distance from pivot resulting in 0.13mm Maximum deflection (Straight Arm Style)

"X" Dim. (mm)	Force (N)
125	113
100	165
75	291

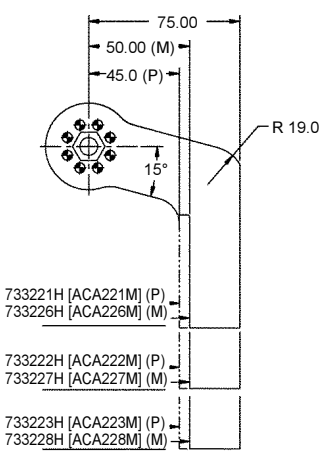
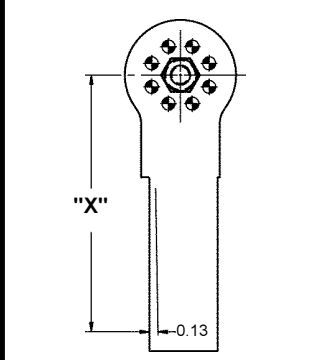

45 & 50 OFFSET

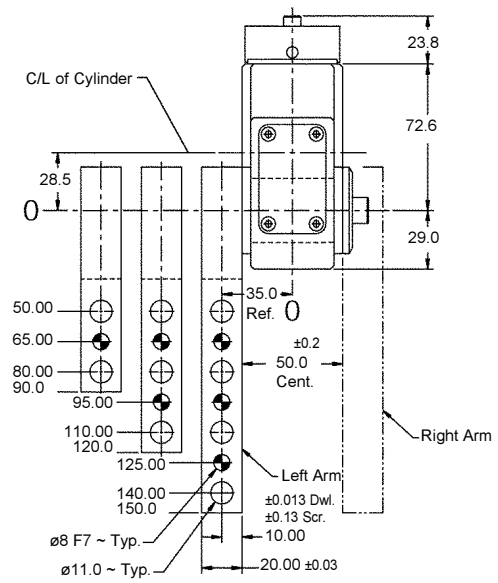

Tolerance Between Arm Holes
 ± 0.03 Between Dowels
 ± 0.13 To Screw Holes

Recommended operating pressure:
 5.5 - 7 bars (80 - 100 PSI)
 Compressed air
 Use flow controls to reduce impact

$$\text{CLAMPING FORCE (N)} = \frac{16 \times 500 \times \text{LINE PRESSURE (Bars)}}{\text{LENGTH FROM POINT "A" TO CENTER LINE OF CLAMPING CONTACT AREA ON CLAMP ARM (mm)}}$$

$$\text{CLAMPING FORCE (lbs.)} = \frac{10 \times \text{LINE PRESSURE (P.S.I.)}}{\text{LENGTH FROM POINT "A" TO CENTER LINE OF CLAMPING CONTACT AREA ON CLAMP ARM (INCHES)}}$$



Manufactured by
 BTM CORPORATION
 Marysville, Michigan USA
 PATENTED

FEATURES

- One body style provides both NAAMS and European mounting patterns
- TRI-LOK mechanism ~ Use as a clamp or back-up
- Sealed mechanism ~ Lubricated for life of clamp
- Integral 52mm (2") oval bore cylinder with heavy wall
- Hardcoated aircraft aluminum body for excellent wear characteristics
- Light weight ~ Approximately 3.2 kg. (7 lbs)
- Pin arm drive for versatile arm positioning & Simplified arm change
- Integrated proximity switch package
- Adjustable cushions standard on both advance and retract ends
- Manual Unlock provision for setup

CAD TEMPLATES AVAILABLE

N.A.A.M.S. Preferred

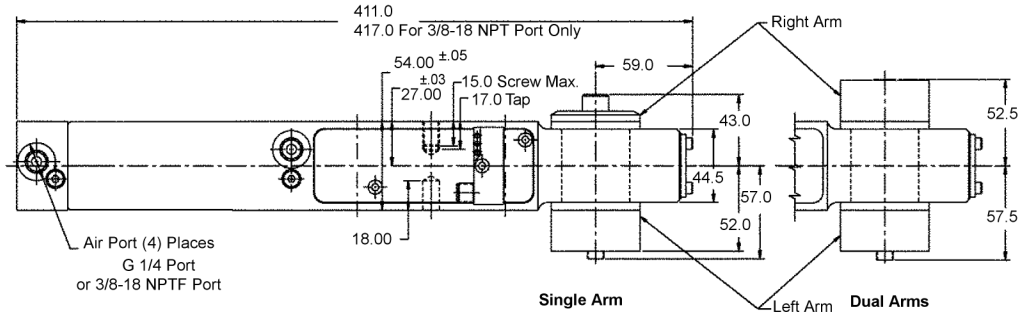

Clamps have a Manual Unlock provision for setup.

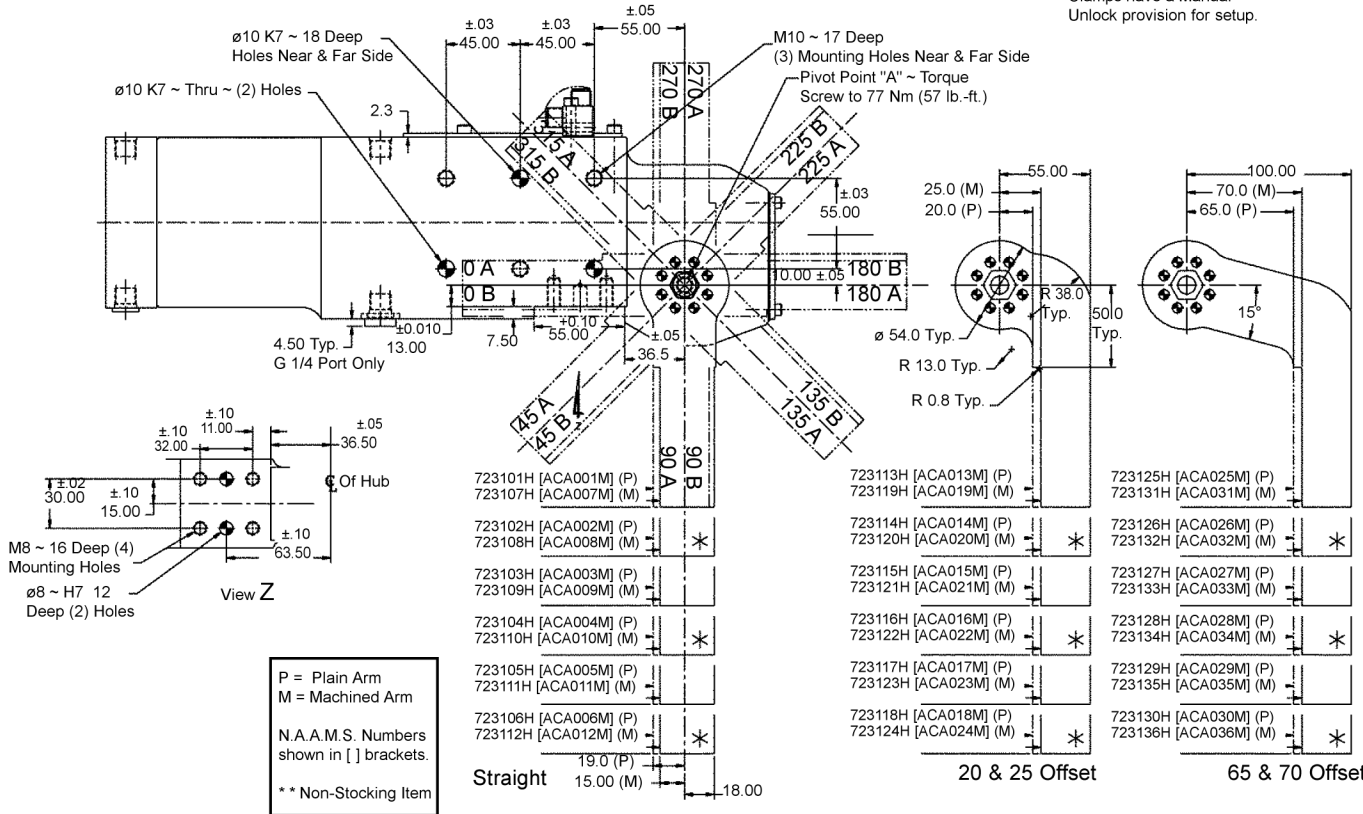

CLAMP ASSEMBLY NUMBERS

ARM OPENING	CYLINDER STROKE	G 1/4 Port		3/8-18 NPTF Port	
		SINGLE ARM	DUAL ARM	SINGLE ARM	DUAL ARM
30°	34.06	733600A	733600J	745100A	745100J
45°	43.67	733600B	733600K	745100B	745100K
60°	53.07	733600C	733600L	745100C	745100L
75°	62.87	733600D	733600M	745100D	745100M
90°	73.18	733600E	733600N	745100E	745100N
105°	80.14	733600F	733600P	745100F	745100P
120°	93.05	733600G	733600R	745100G	745100R

HOW TO ORDER

CLAMP ASSEMBLY NUMBER

ARM STYLE: 723101H THROUGH 723128H

ARM POSITION: 90A, 135A, 180A, 90B, 135B, 180B

ARM LOCATION: L= LEFT SIDE, R= RIGHT SIDE

ARM STYLE: 723101H THROUGH 723128H

ARM POSITION: 90A, 135A, 180A, 90B, 135B, 180B

ARM LOCATION: L= LEFT SIDE, R= RIGHT SIDE

PROX. SWITCH OPTIONS

733300J - 723101H - 90A L - 723101H - 90A R - SC1

LEFT ARM

RIGHT ARM

STC 62 Series Sealed Oval Toggle Clamp ~ Metric Mount

STC62



Standard Switch Package Turck Status Controller DC NI2-Q6.5-AP6-0.20-FS4.4X3/S304	Switch Package Namco C2000 Sensor	Switch Package Pepperl & Fuchs Status Controller DC NBN2-F581-160S6-E8-V1	Cylindicator Switch Block	Cover Block No Switch
<p>SC1 SC2</p>	<p>DC Type 92 EE280-92140 SC2NDC</p> <p>AC Type 92 EE270-92140 SC2NAC</p>	<p>SC1PDC SC2PDC</p> <p>AC NCN2-F58A1-160S6-U8-V125</p> <p>SC1PAC SC2PAC</p>	<p>SP Switches Not Included</p> <p>Not Available For 30° Opening</p>	<p>NS For Use Without Switches</p>

Maximum Weight Allowable On Arm

1 Second Opening & 1 Second Closing Cycle

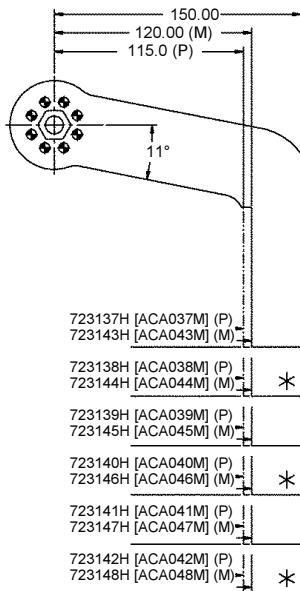
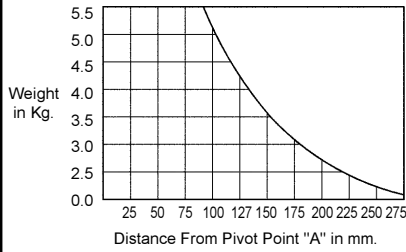

115 & 120 Offset

Tolerance Between Arm Holes
± 0.03 Between Dowels
± 0.13 To Screw Holes

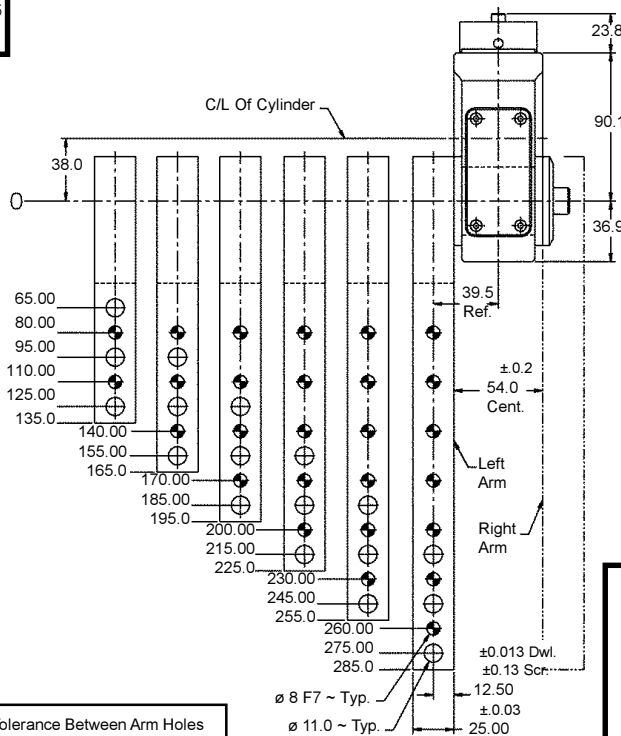

PATENTED AND PATENTS APPLIED FOR

Arm Deflection Under Load
Force on arm at "X" distance from pivot
resulting in 0.13mm Maximum deflection
(Straight Arm Style)

"X" Dim. (mm)	Force (N)
250	156
225	200
200	245
175	289
150	378
125	489
100	734

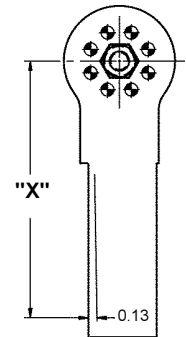

Recommended operating pressure:
5.5 - 7 bars (80 - 100 PSI)
Compressed air
Use Flow controls to reduce impact

$$\text{CLAMPING FORCE (N)} = \frac{46\,500 \times \text{LINE PRESSURE (Bars)}}{\text{LENGTH FROM POINT "A" TO CENTER LINE OF CLAMP CONTACT AREA ON CLAMP ARM (mm)}}$$

$$\text{CLAMPING FORCE (lbs.)} = \frac{28.5 \times \text{LINE PRESSURE (P.S.I.)}}{\text{LENGTH FROM POINT "A" TO CENTER LINE OF CLAMP CONTACT AREA ON CLAMP ARM (INCHES)}}$$



Manufactured by
BTM CORPORATION
Marysville, Michigan USA
PATENTED

FEATURES

- One body style provides both NAAMS and European mounting patterns
- TRI-LOK mechanism ~ Use as a clamp or back-up
- Sealed mechanism ~ Lubricated for life of clamp
- Integral 62mm (2.5") oval bore cylinder with heavy wall
- Hardcoated aircraft aluminum body for excellent wear characteristics
- Light weight ~ Approximately 5.5 kg. (12 lbs)
- Pin arm drive for versatile arm positioning & Simplified arm change
- Integrated proximity switch package or standard proximity switches
- Adjustable cushions standard on both advance and retract ends
- Manual Unlock provision for setup

CAD TEMPLATES AVAILABLE
N.A.A.M.S. Preferred

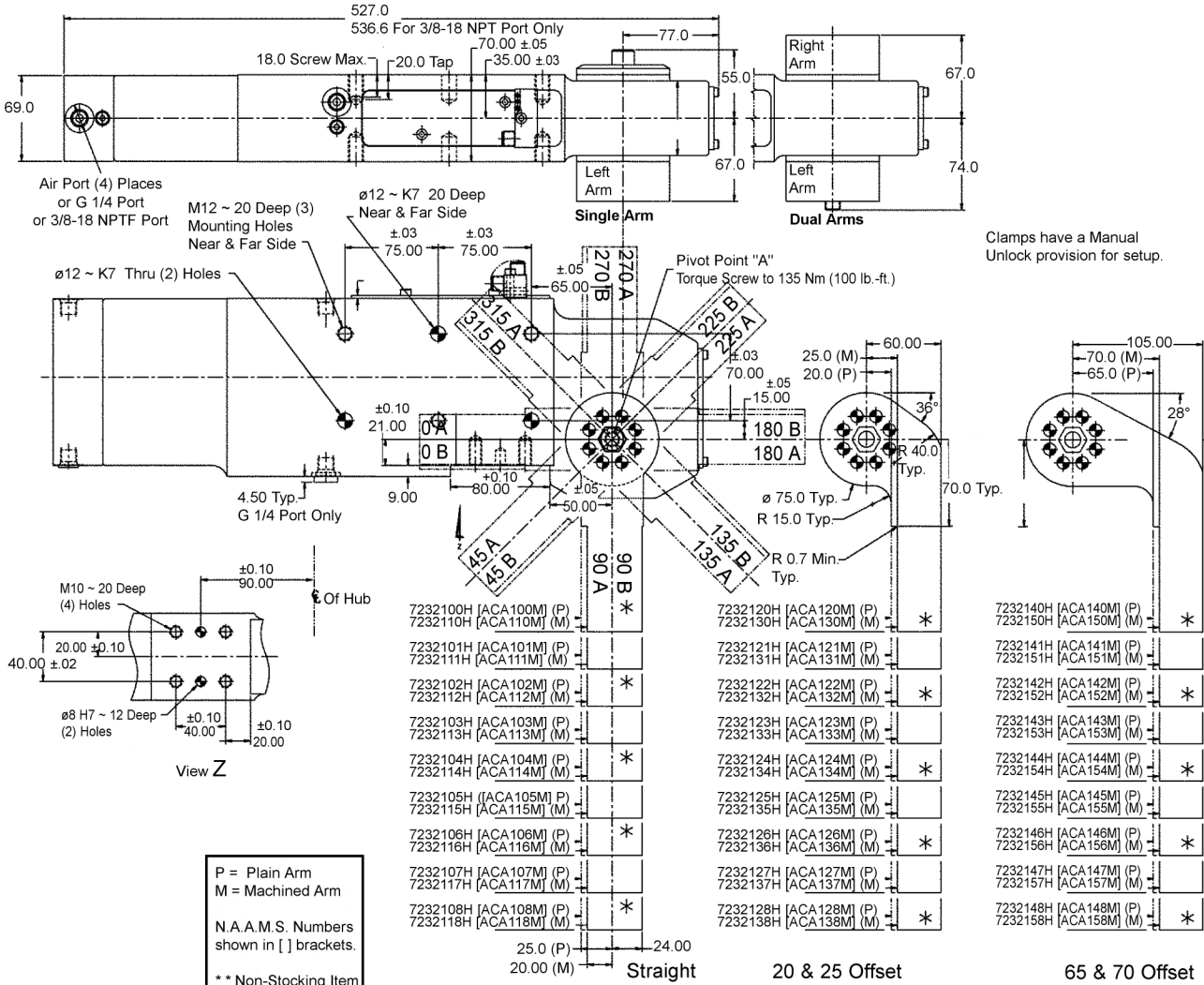

Clamps have a Manual Unlock provision for setup.

CLAMP ASSEMBLY NUMBERS

ARM OPENING	CYLINDER STROKE	G 1/4 Port		3/8-18 NPTF Port	
		SINGLE ARM	DUAL ARM	SINGLE ARM	DUAL ARM
30°	34.06	733700A	733700J	745200A	745200J
45°	43.67	733700B	733700K	745200B	745200K
60°	53.07	733700C	733700L	745200C	745200L
75°	62.87	733700D	733700M	745200D	745200M
90°	73.18	733700E	733700N	745200E	745200N
105°	80.14	733700F	733700P	745200F	745200P
120°	93.05	733700G	733700R	745200G	745200R

HOW TO ORDER

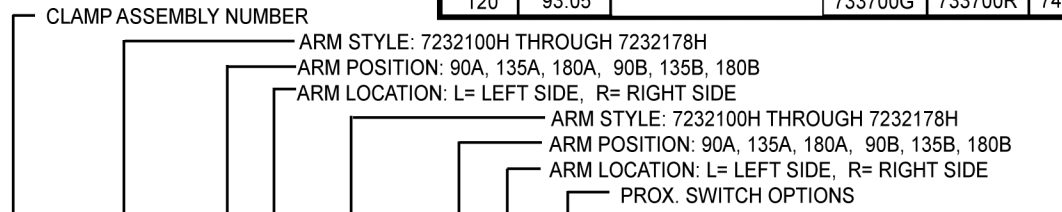

733400J - 7232100H - 90A L - 7232100H - 90A R - SC1
LEFT ARM RIGHT ARM

STC 82 Series Sealed Oval Toggle Clamp ~ Metric Mount

STC82



Standard Switch Package Turck Status Controller DC NI2-Q6.5-AP6-0.20-FS4.4X3/S304 AC NI2-Q6.5-ADZ32-0.16-FSB5.4X4/S304 	Switch Package Namco C2000 Sensor DC Type 92 EE280-92140 SC2NDC AC Type 92 EE270-92140 SC2NAC 	Switch Package Pepperl & Fuchs Status Controller DC NBN2-F581-160S6-E8-V1 AC NCN2-F58A1-160S6-U8-V125 	Cylindactor Switch Block SP Switches Not Included Not Available For 30° Opening	Cover Block No Switch NS For Use Without Switches
--	---	---	--	---

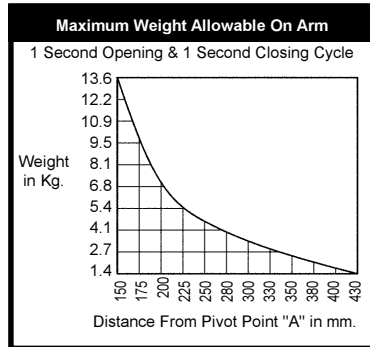

TRI-LOK
 PATENTED AND PATENTS APPLIED FOR

Arm Deflection Under Load
 Force on arm at "X" distance from pivot resulting in 0.13mm Maximum deflection (Straight Arm Style)

"X" Dim. (mm)	Force (N)
370	165
340	205
310	267
280	365
250	449
220	623
190	1005
160	1397
130	2073
100	3065

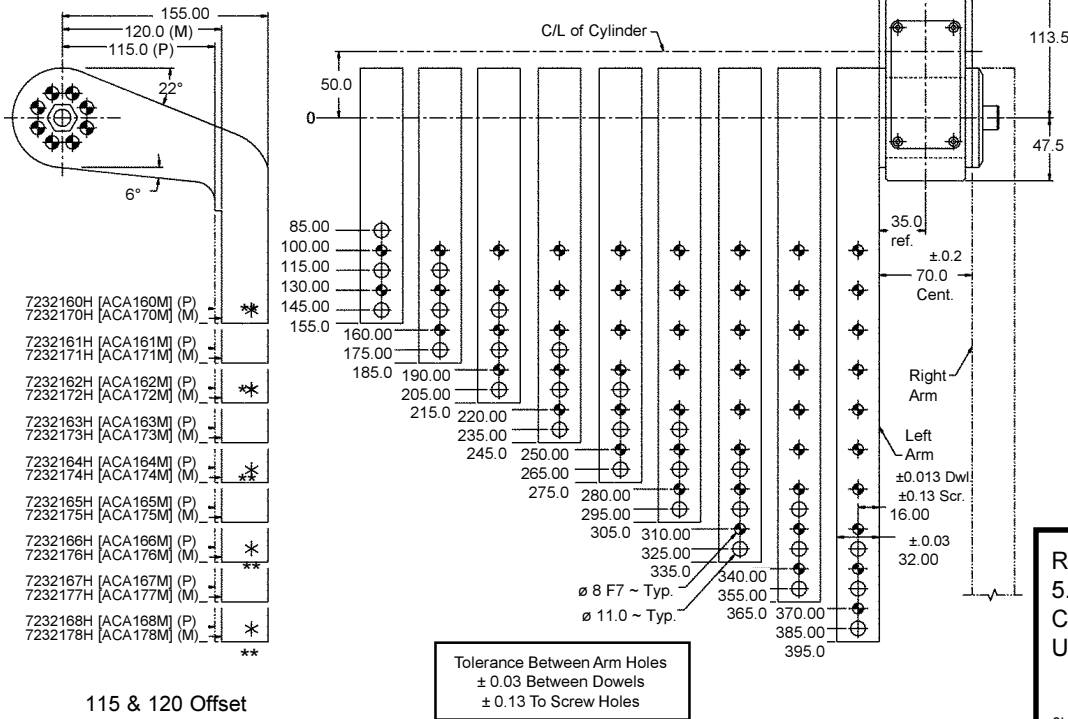
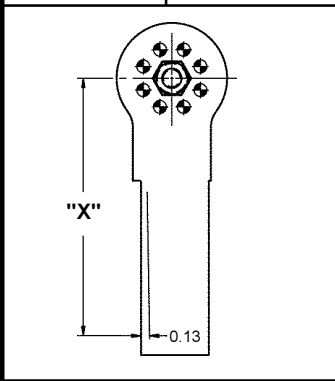

Recommended operating pressure:
 5.5 - 7 bars (80 - 100 PSI)
 Compressed air
 Use Flow controls to reduce impact

CLAMPING FORCE (N) = $\frac{92,000 \times \text{LINE PRESSURE (Bars)}}{\text{LENGTH FROM POINT "A" TO CENTER LINE OF CLAMPING CONTACT AREA ON CLAMP ARM (mm)}}$

CLAMPING FORCE (lbs.) = $\frac{55 \times \text{LINE PRESSURE (P.S.I.)}}{\text{LENGTH FROM POINT "A" TO CENTER LINE OF CLAMPING CONTACT AREA ON CLAMP ARM (INCHES)}}$

BTM CORPORATION
 Manufactured by BTM CORPORATION
 Marysville, Michigan USA
 PATENTED

- FEATURES**
- One body style provides both NAAMS and European mounting patterns
 - TRI-LOK mechanism ~ Use as a clamp or back-up
 - Sealed mechanism ~ Lubricated for life of clamp
 - Integral 82mm (3.25") oval bore cylinder with heavy wall
 - Hardcoated aircraft aluminum body for excellent wear characteristics
 - Light weight ~ Approximately 13.6 kg. (30 lbs)
 - Pin arm drive for versatile arm positioning & Simplified arm change
 - Integrated proximity switch package or standard proximity switches
 - Adjustable cushions standard on both advance and retract ends
 - Manual Unlock provision for setup

Sealed Offset Power Clamps

PC 1500 SO • PC 2500 SO

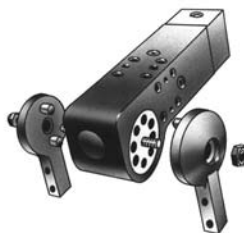

BTM's Pin drive arms allow fast changeover without disassembly of the sealed internal mechanism.

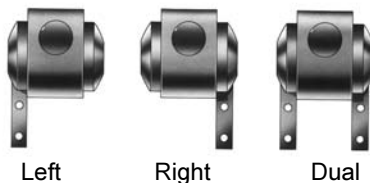

Clamp arms can be mounted left, right or dual without modification.

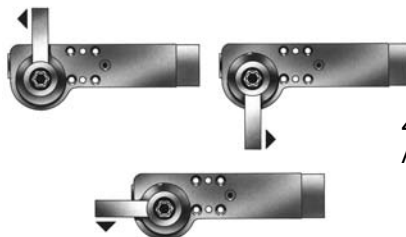

45° Interchangeable Arm Positions

FEATURES

- One piece body ~ Integral cylinder with heavy wall.
- Sealed mechanism ~ Lubricated for life of clamp.
- Positive Locking Toggle Action
- Hardcoated aircraft aluminum body.
- Pin arm drive for simplified arm change & positioning.
- Optional pre-fitted proximity switches.
- Light weight.

PC 1500 SO
BTM No. 700100A

PC 2500 SO
BTM No. 700200A

AAP Option

Adjustable Arm Positioning

- **This feature allows precise $\pm 2^\circ$ adjustment of the arm's closed position.**
- **The set position will repeat accurately.**
- **The arm can be mounted in any one of eight positions on either right or left side.**

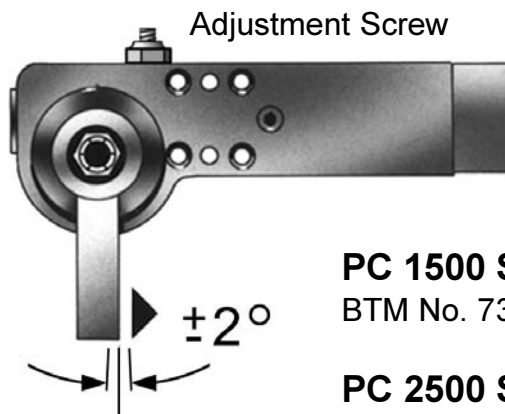

Repeatable Arm Position With Adjustment Of $\pm 2^\circ$.

PC 1500 SO AAP
BTM No. 737900A

PC 2500 SO AAP
BTM No. 738000A

BTM
CORPORATION

1500 Series Sealed Offset Power Toggle Clamp

PC 1500 SO & PC 1500 SO AAP



Maximum Weight Allowable On Arm

1 Second Opening & 1 Second Closing Cycle

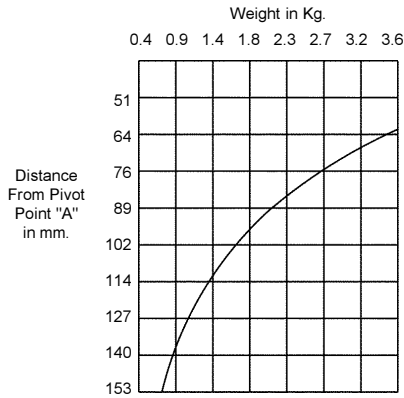

SPECIFICATIONS

Bore ϕ : 38mm (1.5")
 Stroke: 43mm (1.69") MAX.
 Arm Opening: 130° MAX.
 Recommended operating pressure:
 5.5 - 7 bars (80 - 100 PSI)
 Use Flow controls to reduce impact
 Approx. Weight: 2Kg (4.5 lbs.)



Manufactured by
 BTM CORPORATION
 Marysville, Michigan USA
 PATENTED

OPTIONAL OVER-CENTER
 LOCKING AVAILABLE

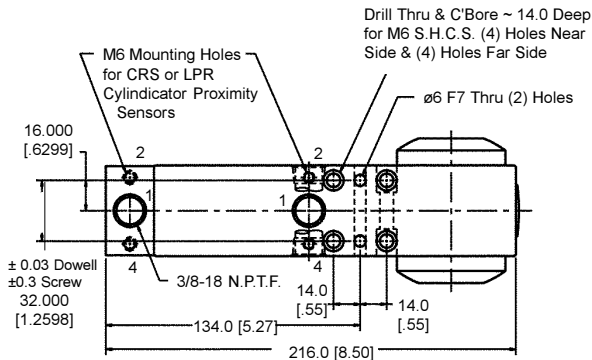

M6 Mounting Holes for CRS or LPR
 Cylindicator Proximity Sensors

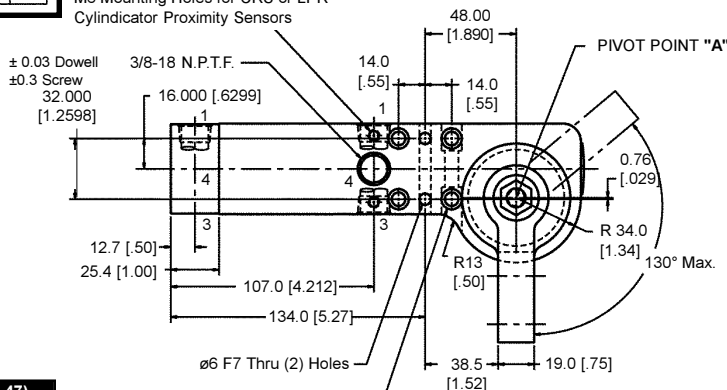
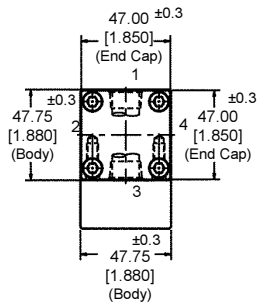

Drill Thru & C'Bore ~ 14.0 Deep for
 M6 S.H.C.S. (4) Holes Near Side &
 (4) Holes Far Side

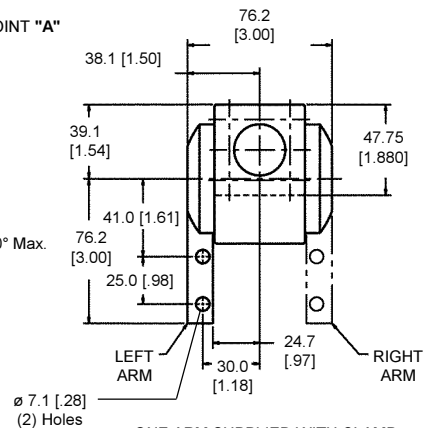

ONE ARM SUPPLIED WITH CLAMP

OPTIONAL PROXIMITY SWITCHES (SEE PG. 47)

Cylindicator Switch

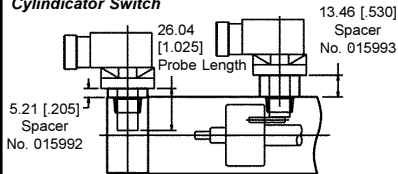

NOTE:
 •Ports Will Be In Position 1 Unless
 Otherwise Specified.
 •Rear Prox. Is 180° To Port Position.
 •Rotate End Cap 90° for Rear Port
 Positions 2 & 4, 180° for Position 3

BTM Switch

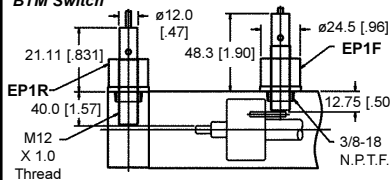

NAMCO LPR CYLINDICATOR:
 LPR1 = EE230-10420 (MINI CONNECTOR)
 LPR2 = EE230-10422 (MICRO CONNECTOR)
 TURCK CRS CYLINDER POSITION INDICATOR:
 CRS1 = BI2-CRS-260-ADZ30X2-B1131/S34 (MINI CONNECTOR)
 CRS2 = BI2-CRS-260-ADZ30X2-B3131/S34 (MICRO CONNECTOR)
 BTM PROXIMITY SWITCH W/ ADAPTER:
 BES1 = BTM NO. 006266 (AC)
 BES2 = BTM NO. 006463 (DC)

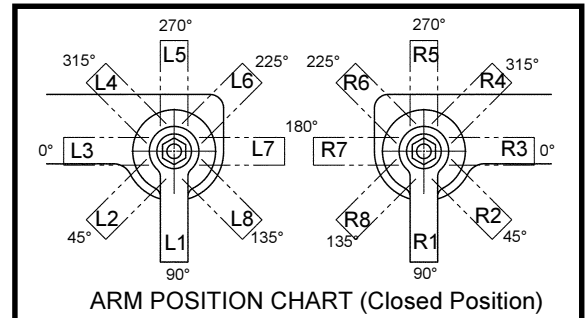

ARM POSITION CHART (Closed Position)

$$\text{CLAMP FORCE (lbs)} = \frac{4 \times \text{LINE PRESSURE (P.S.I.)}}{\text{LENGTH FROM POINT 'A' TO CENTER LINE OF CLAMPING CONTACT AREA ON ARM (INCHES)}}$$

HOW TO ORDER

POWER CLAMP

1500 SERIES: 1.5" BORE

CLAMP STYLE: SEALED OFFSET

ARM OPENING: 15, 30, 60, 90, 130

ARM LOCATION: L= LEFT SIDE, R= RIGHT SIDE, D= DUAL

LEFT ARM POSITION: L1, L2, L3, L4, L5, L6, L7, L8

RIGHT ARM POSITION: R1, R2, R3, R4, R5, R6, R7, R8

FRONT PORT POSITION: FP1, FP2, FP3, FP4

REAR PORT POSITION: RP1, RP2, RP3, RP4

PROX. SWITCH: LPR1, LPR2, CRS1, CRS2, BES1, BES2

FRONT PROX. POSITION: EP1F, EP2F, EP3F, EP4F

REAR PROX. POSITION: EP1R, EP2R, EP3R, EP4R

SWITCH TYPE: AC OR DC

BTM PC-1500-SO -130 -D -L1 -R7 -FP4 -RP1 -LPR1 -EP2F -EP3R -AC

BTM No. 700100A

OPTIONS

OPTIONAL OVER-CENTER
 LOCKING AVAILABLE

PC 1500 SO

BTM No. 700100A

PC 1500 SO AAP

BTM No. 737900A

2500 Series Sealed Offset Power Toggle Clamp

PC 2500 SO & PC 2500 SO AAP

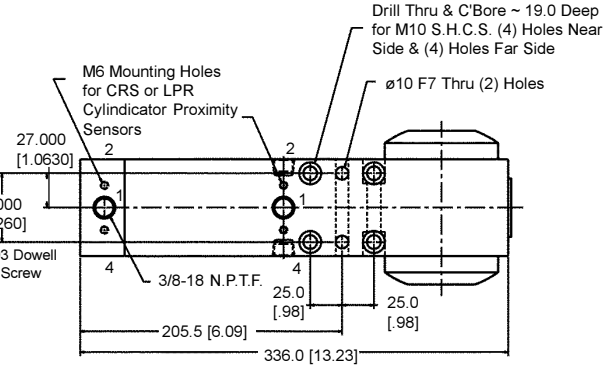
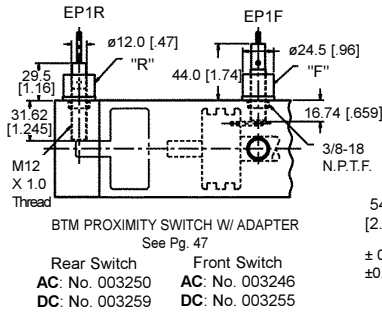

SPECIFICATIONS

Bore \varnothing : 63.5mm (2.5")
 Stroke: 72mm (2.83") MAX.
 Arm Opening: 130° MAX.
 Recommended operating pressure: 5.5 - 7 bars (80 - 100 PSI)
 Use Flow controls to reduce impact
 Approx. Weight: 9Kg (20 lbs.)



Manufactured by
 BTM CORPORATION
 Marysville, Michigan USA
 PATENTED

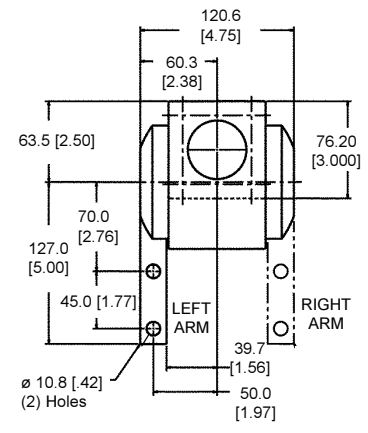
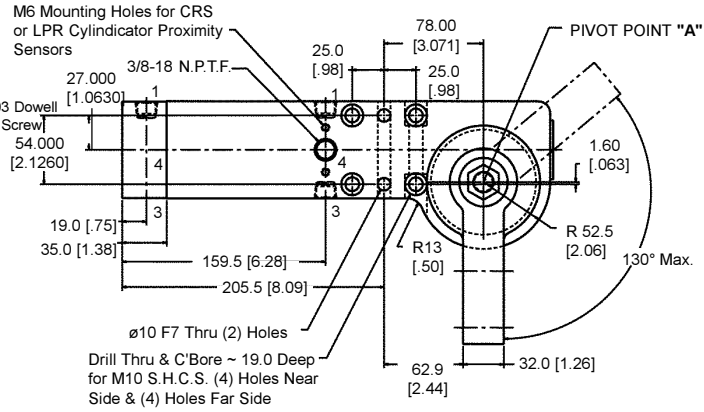
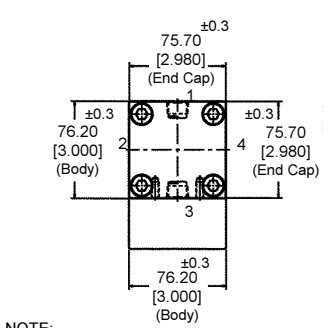

ONE ARM SUPPLIED WITH CLAMP

NOTE:
 Ports Will Be In Position 1 Unless Otherwise Specified.
 Rear Prox. Is 180° To Port Position.
 Rotate End Cap
 90° for Rear Port Positions 2 & 4
 180° for Position 3

$$\text{CLAMP FORCE (N)} = \frac{24\ 650 \times \text{LINE PRESSURE (bars)}}{\text{LENGTH FROM POINT "A" TO CENTER LINE OF CLAMPING CONTACT AREA ON ARM (mm)}}$$

$$\text{CLAMP FORCE (lbs)} = \frac{15 \times \text{LINE PRESSURE (P.S.I.)}}{\text{LENGTH FROM POINT "A" TO CENTER LINE OF CLAMPING CONTACT AREA ON ARM (INCHES)}}$$

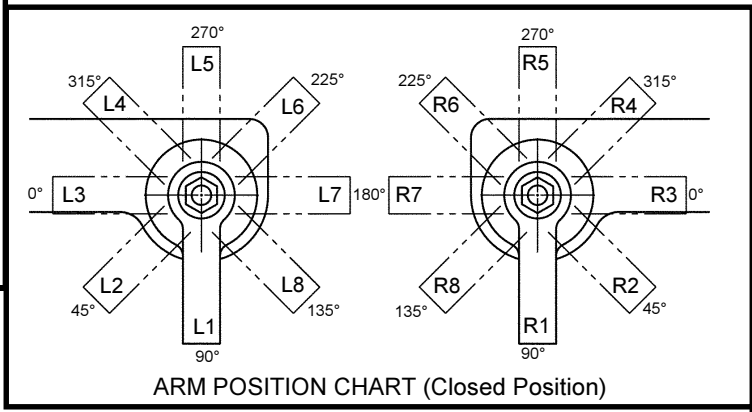

HOW TO ORDER

POWER CLAMP
 2500 SERIES: 2.5" BORE
 CLAMP STYLE: SEALED OFFSET
 ARM OPENING: 15, 30, 60, 90, 130
 ARM LOCATION: L= LEFT SIDE, R= RIGHT SIDE, D= DUAL
 LEFT ARM POSITION: L1, L2, L3, L4, L5, L6, L7, L8
 RIGHT ARM POSITION: R1, R2, R3, R4, R5, R6, R7, R8
 FRONT PORT POSITION: FP1, FP2, FP3, FP4
 REAR PORT POSITION: RP1, RP2, RP3, RP4
 FRONT PROX. POSITION: EP1F, EP2F, EP3F, EP4F
 REAR PROX. POSITION: EP1R, EP2R, EP3R, EP4R
 SWITCH TYPE: AC OR DC

PC 2500 SO

BTM No. 700200A

PC 2500 SO AAP

BTM No. 738000A

BTM PC-2500-SO -130 -D -L1 -R7 -FP4 -RP1 -EP2F -EP3R -AC
 BTM No. 700200A OPTIONS

OPTIONAL OVER-CENTER
 LOCKING AVAILABLE

1500 Series Power Toggle Clamp

PC 1500-V 130



CAD TEMPLATES AVAILABLE

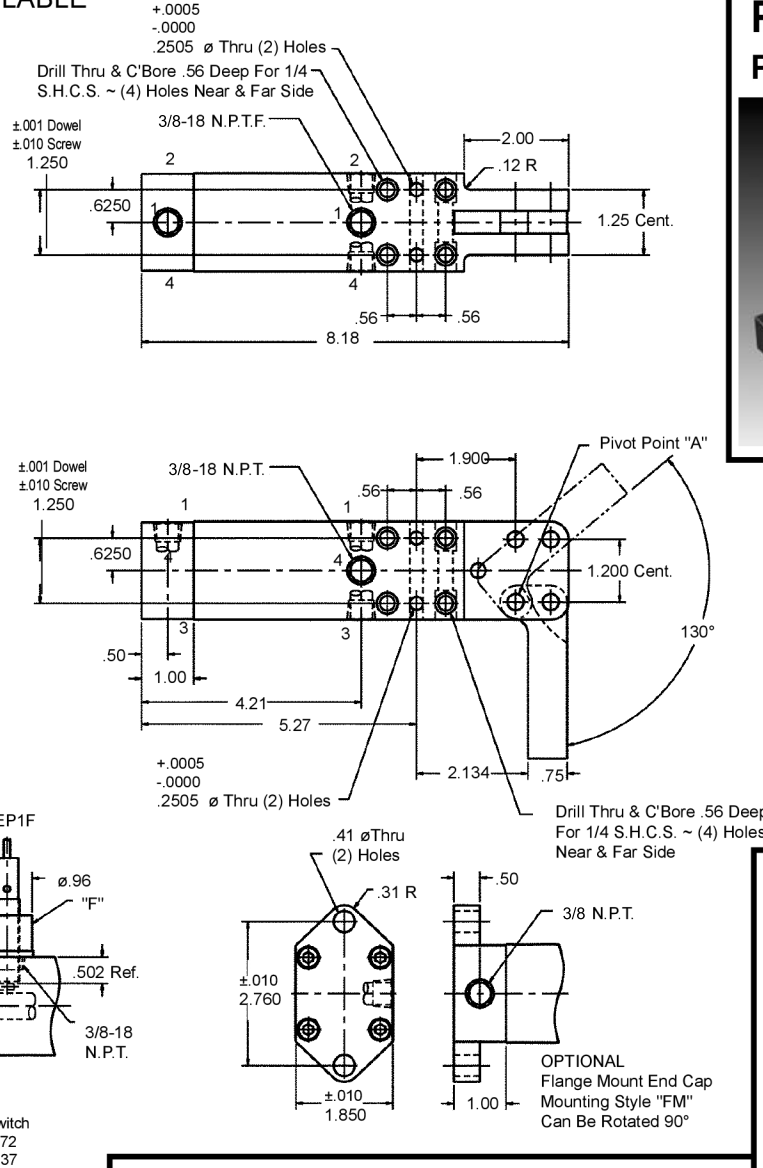

Power Toggle Clamps PC 1500 & PC 2500 Series

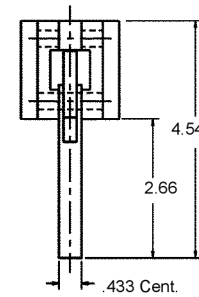
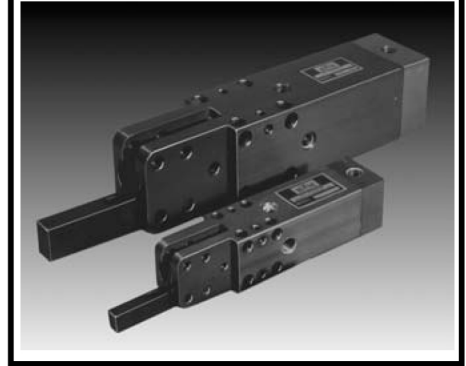

FEATURES

- One piece body
- Integral cylinder
- Positive Locking Toggle
- Light weight.

SPECIFICATIONS

Bore ϕ : 1.5"
 Stroke: 1.699"
 Arm Opening: 130°
 Recommended operating pressure:
 80 - 100 PSI
 Use Flow controls to reduce impact
 Approx. Weight: 3 lbs.



Manufactured by
 BTM CORPORATION
 Marysville, Michigan USA
 PATENTED

$$\text{CLAMP FORCE (lbs)} = \frac{4 \times \text{LINE PRESSURE (P.S.I.)}}{\text{LENGTH FROM POINT "A" TO CENTER LINE OF CLAMPING CONTACT AREA ON ARM (INCHES)}}$$

HOW TO ORDER

POWER CLAMP
 1500 SERIES: 1.5" BORE
 ARM OPENING: VERTICAL 130°
 MOUNTING STYLE: FM FLANGE MOUNT
 FRONT PORT POSITION: FP1, FP2, FP3, FP4
 REAR PORT POSITION: RP1, RP2, RP3, RP4
 FRONT PROX. POSITION: EP1F, EP2F, EP3F, EP4F
 REAR PROX. POSITION: EP1R, EP2R, EP3R, EP4R
 SWITCH TYPE: AC OR DC

BTM PC-1500-V130 - FM -FP4 -RP1 -EP2F -EP3R -AC

Body Mount No. 001635
 Flange Mount No. 012503

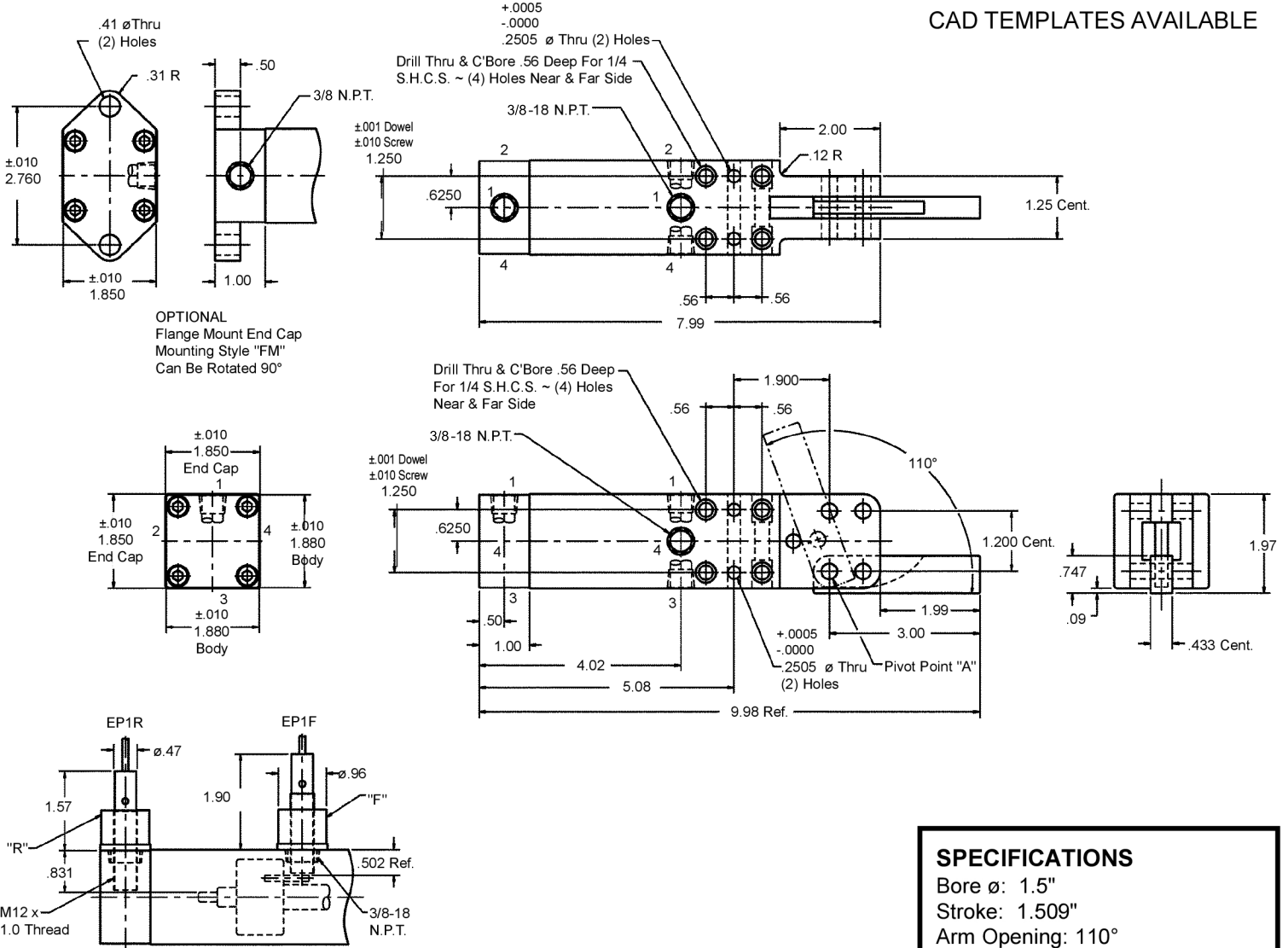

OPTIONAL
Flange Mount End Cap
Mounting Style "FM"
Can Be Rotated 90°

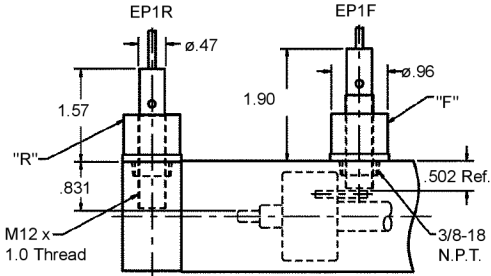
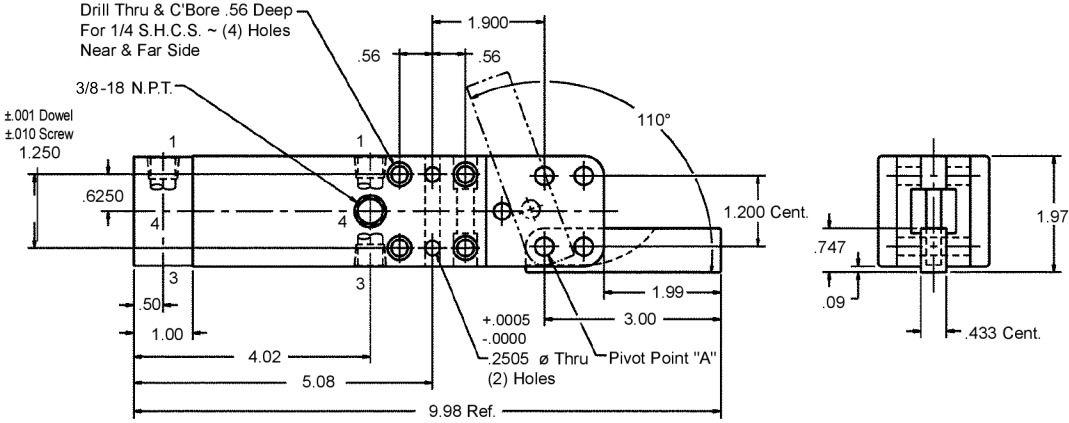

Dimensions For Optional
Electrical Proximity Switches

"R" = Rear Switch AC: No. 003176 DC: No. 003241
"F" = Front Switch AC: No. 003172 DC: No. 003237

OPTIONAL PROXIMITY SWITCHES (SEE PG. 47)

SPECIFICATIONS

Bore ø: 1.5"
Stroke: 1.509"
Arm Opening: 110°
Recommended operating pressure:
80 - 100 PSI
Use Flow controls to reduce impact
Approx. Weight: 3 lbs.

$$\text{CLAMP FORCE (lbs)} = \frac{4 \times \text{LINE PRESSURE (P.S.I.)}}{\text{LENGTH FROM POINT "A" TO CENTER LINE OF CLAMPING CONTACT AREA ON ARM (INCHES)}}$$



Manufactured by
BTM CORPORATION
Marysville, Michigan USA
PATENTED

HOW TO ORDER

POWER CLAMP
1500 SERIES: 1.5" BORE
ARM OPENING: HORIZONTAL 110°
MOUNTING STYLE: FM FLANGE MOUNT
FRONT PORT POSITION: FP1, FP2, FP3, FP4
REAR PORT POSITION: RP1, RP2, RP3, RP4
FRONT PROX. POSITION: EP1F, EP2F, EP3F, EP4F
REAR PROX. POSITION: EP1R, EP2R, EP3R, EP4R
SWITCH TYPE: AC OR DC

BTM PC-1500-H110 - FM -FP4 -RP1 -EP2F -EP3R -AC

Body Mount No. 001666
Flange Mount No. 012505

OPTIONS

1500 Series Power Toggle Clamp

PC 1500-PL .98



CAD TEMPLATES AVAILABLE

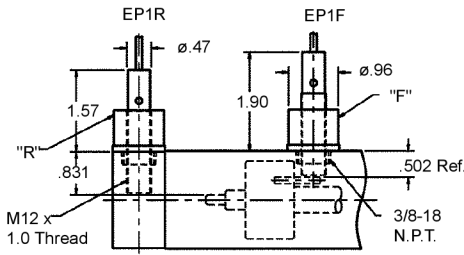

Dimensions For Optional Electrical Proximity Switches

"R" = Rear Switch
AC: No. 003176
DC: No. 003241

"F" = Front Switch
AC: No. 003172
DC: No. 003237

OPTIONAL PROXIMITY SWITCHES (SEE PG. 47)

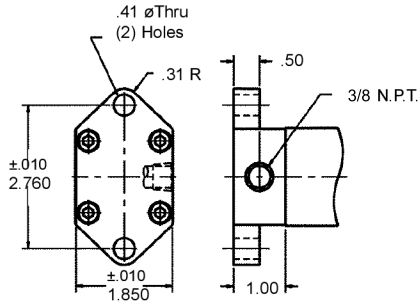
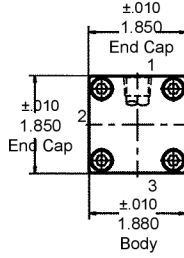
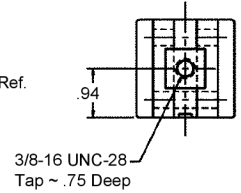
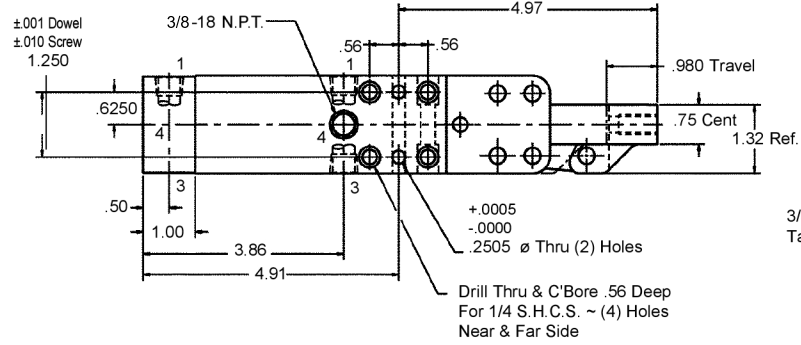
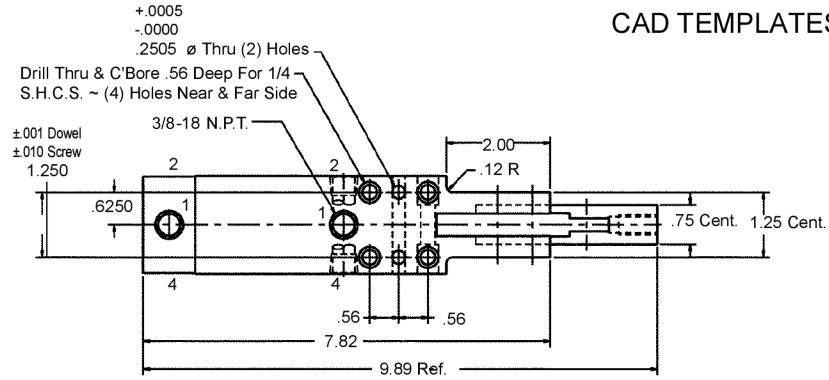

OPTIONAL Flange Mount End Cap Mounting Style "FM" Can Be Rotated 90°

Force In lbs.
@ 80 PSI

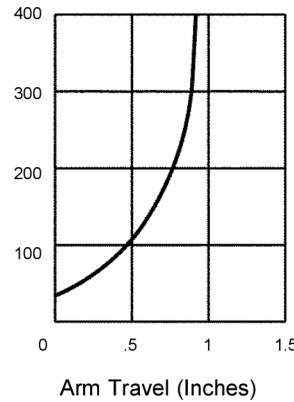

SPECIFICATIONS

Bore ø: 1.5"
Stroke: 1.344"
Arm Opening: .98"
Recommended operating pressure:
80 - 100 PSI
Use Flow controls to reduce impact
Approx. Weight: 3 lbs.



Manufactured by
BTM CORPORATION
Marysville, Michigan USA
PATENTED

HOW TO ORDER

POWER CLAMP
1500 SERIES: 1.5" BORE
ARM OPENING: LINEAR .98"
MOUNTING STYLE: FM FLANGE MOUNT
FRONT PORT POSITION: FP1, FP2, FP3, FP4
REAR PORT POSITION: RP1, RP2, RP3, RP4
FRONT PROX. POSITION: EP1F, EP2F, EP3F, EP4F
REAR PROX. POSITION: EP1R, EP2R, EP3R, EP4R
SWITCH TYPE: AC OR DC

BTM PC-1500-PL .98 -FM -FP4 -RP1 -EP2F -EP3R -AC

Body Mount No. 012500
Flange Mount No. 012501

OPTIONS

OPTIONAL PROXIMITY SWITCHES (SEE PG. 47)

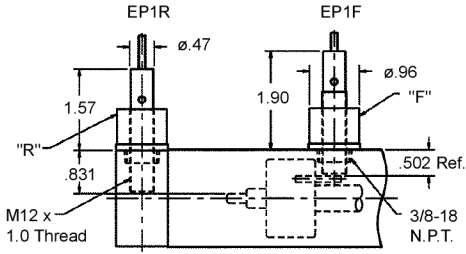

Dimensions For Optional Electrical Proximity Switches

"R" = Rear Switch AC: No. 003176 DC: No. 003241
 "F" = Front Switch AC: No. 003172 DC: No. 003237

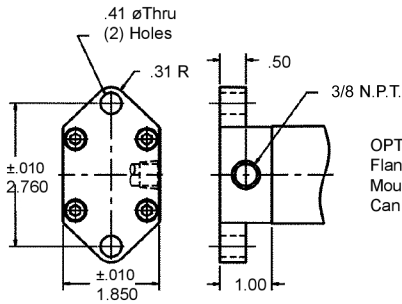
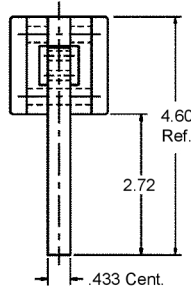
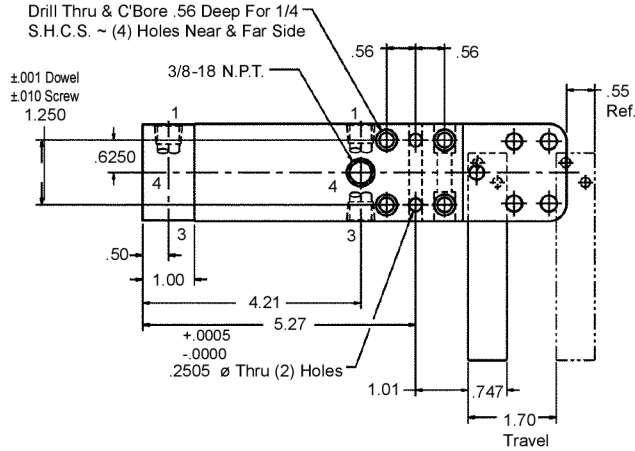
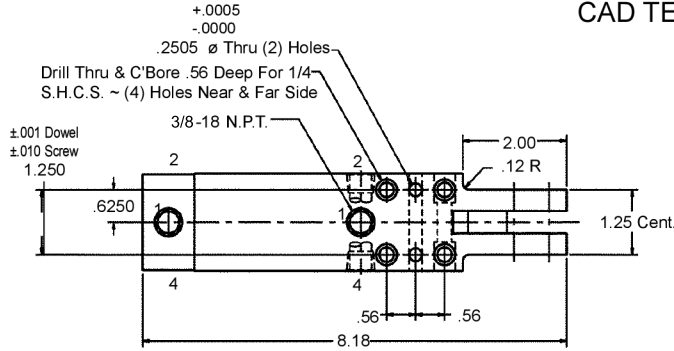
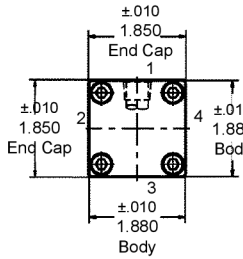

OPTIONAL Flange Mount End Cap Mounting Style "FM" Can Be Rotated 90°

CLAMP FORCE (lbs) = 1.4 X LINE PRESSURE (P.S.I.)

SPECIFICATIONS
 Bore ø: 1.5"
 Stroke: 1.699"
 Arm Opening: 1.70"
 Slide Clamp = No Toggle Action
 Recommended operating pressure: 80 - 100 PSI
 Use Flow controls to reduce impact
 Approx. Weight: 3 lbs.

Manufactured by BTM CORPORATION Marysville, Michigan USA PATENTED

HOW TO ORDER

- POWER CLAMP
- 1500 SERIES: 1.5" BORE
- ARM OPENING: LINEAR 1.7"
- MOUNTING STYLE: FM FLANGE MOUNT
- FRONT PORT POSITION: FP1, FP2, FP3, FP4
- REAR PORT POSITION: RP1, RP2, RP3, RP4
- FRONT PROX. POSITION: EP1F, EP2F, EP3F, EP4F
- REAR PROX. POSITION: EP1R, EP2R, EP3R, EP4R
- SWITCH TYPE: AC OR DC

BTM PC-1500-SL 1.7 -FM -FP4 -RP1 -EP2F -EP3R -AC

Body Mount No. 001658
 Flange Mount No. 012507

OPTIONS

2500 Series Power Toggle Clamp

PC 2500-V 130



CAD TEMPLATES AVAILABLE

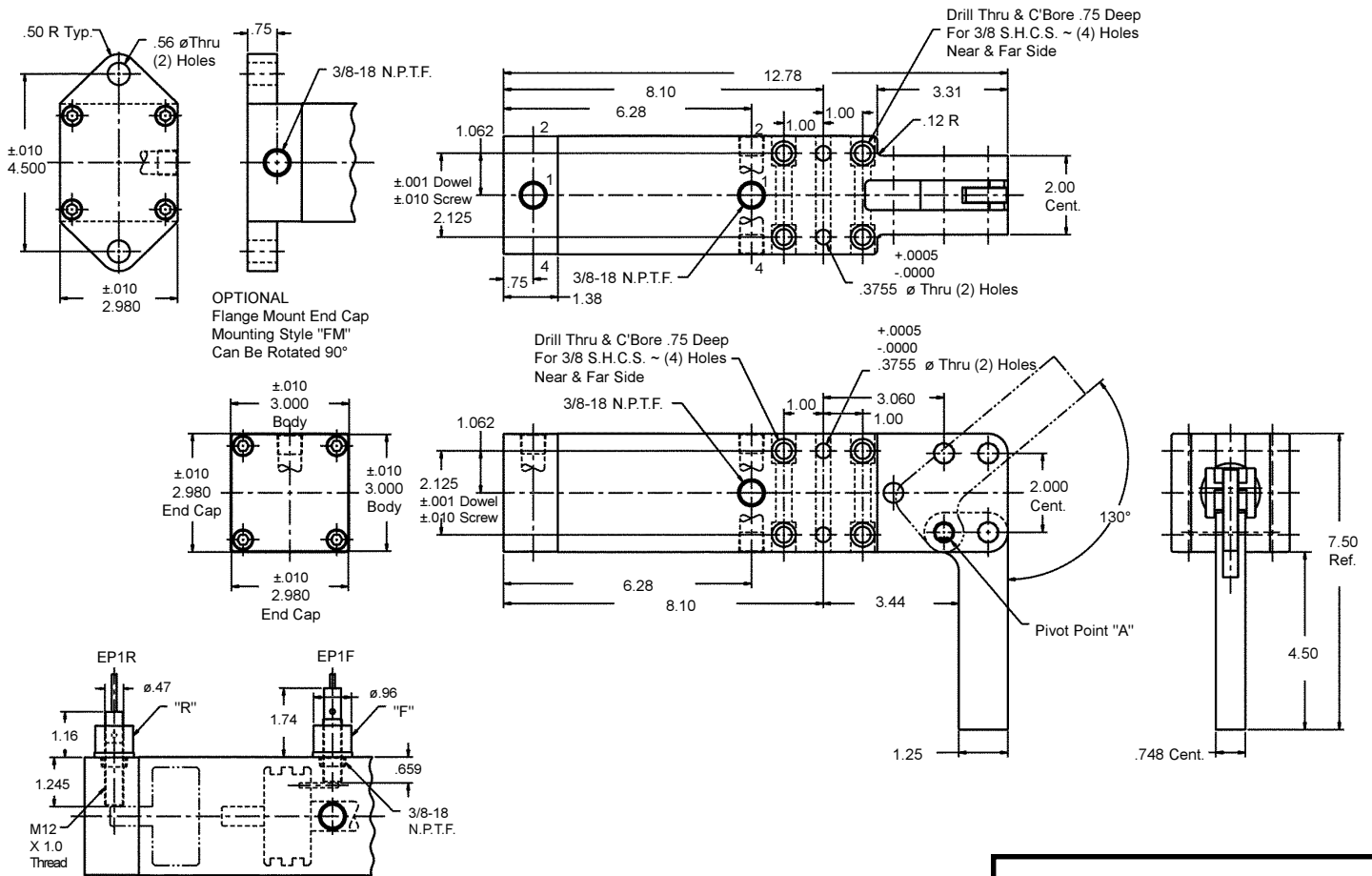

Dimensions For Optional Electrical Proximity Switches
 "R" = Rear Switch AC: No. 003250 DC: No. 003259
 "F" = Front Switch AC: No. 003246 DC: No. 003255
OPTIONAL PROXIMITY SWITCHES (SEE PG. 47)

SPECIFICATIONS
 Bore \varnothing : 2.5"
 Stroke: 2.83"
 Arm Opening: 130°
 Recommended operating pressure: 80 - 100 PSI
 Use Flow controls to reduce impact
 Approx. Weight: 11 lbs.

BTM CORPORATION
 Manufactured by BTM CORPORATION
 Marysville, Michigan USA
PATENTED

$$\text{CLAMP FORCE (lbs)} = \frac{15 \times \text{LINE PRESSURE (P.S.I.)}}{\text{LENGTH FROM POINT "A" TO CENTER LINE OF CLAMPING CONTACT AREA ON ARM (INCHES)}}$$

HOW TO ORDER

- POWER CLAMP
- 2500 SERIES: 2.5" BORE
- ARM OPENING: VERTICAL 130°
- MOUNTING STYLE: FM FLANGE MOUNT
- FRONT PORT POSITION: FP1, FP2, FP3, FP4
- REAR PORT POSITION: RP1, RP2, RP3, RP4
- FRONT PROX. POSITION: EP1F, EP2F, EP3F, EP4F
- REAR PROX. POSITION: EP1R, EP2R, EP3R, EP4R
- SWITCH TYPE: AC OR DC

BTM PC-2500-V130 - FM -FP4 -RP1 -EP2F -EP3R -AC
 Body Mount No. 001411 OPTIONS
 Flange Mount No. 012511

CAD TEMPLATES AVAILABLE

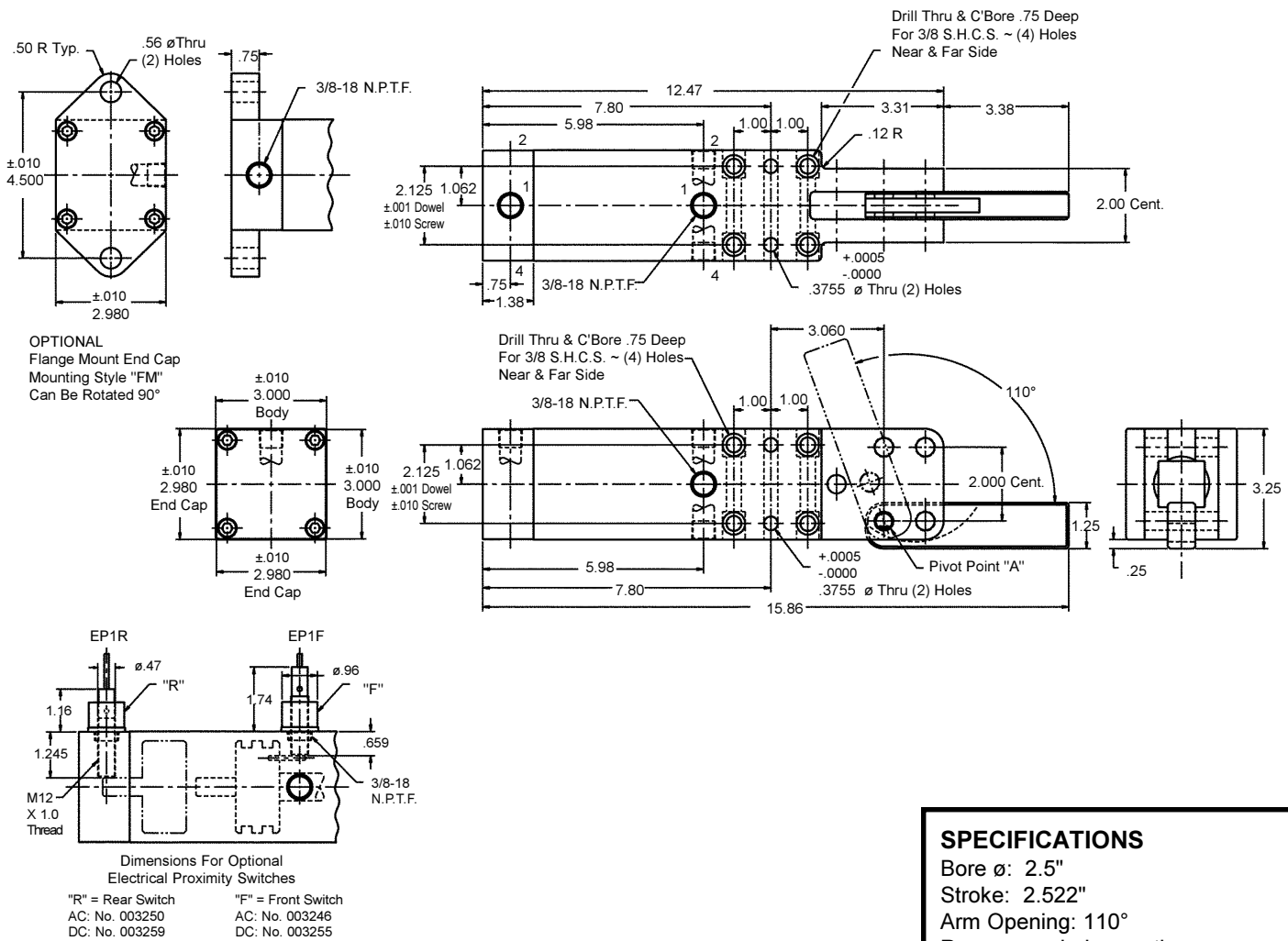

OPTIONAL PROXIMITY SWITCHES (SEE PG. 47)

SPECIFICATIONS

Bore \varnothing : 2.5"
 Stroke: 2.522"
 Arm Opening: 110°
 Recommended operating pressure:
 80 - 100 PSI
 Use Flow controls to reduce impact
 Approx. Weight: 11 lbs.

BTM
CORPORATION

Manufactured by
 BTM CORPORATION
 Marysville, Michigan USA
 PATENTED

$$\text{CLAMP FORCE (lbs)} = \frac{15 \times \text{LINE PRESSURE (P.S.I.)}}{\text{LENGTH FROM POINT "A" TO CENTER LINE OF CLAMPING CONTACT AREA ON ARM (INCHES)}}$$

HOW TO ORDER

- POWER CLAMP
- 2500 SERIES: 2.5" BORE
- ARM OPENING: HORIZONTAL 110°
- MOUNTING STYLE: FM FLANGE MOUNT
- FRONT PORT POSITION: FP1, FP2, FP3, FP4
- REAR PORT POSITION: RP1, RP2, RP3, RP4
- FRONT PROX. POSITION: EP1F, EP2F, EP3F, EP4F
- REAR PROX. POSITION: EP1R, EP2R, EP3R, EP4R
- SWITCH TYPE: AC OR DC

BTM PC-2500-H110 - FM -FP4 -RP1 -EP2F -EP3R -AC

Body Mount No. 001444 OPTIONS
 Flange Mount No. 012514

2500 Series Power Toggle Clamp

PC 2500-PL 1.6



CAD TEMPLATES AVAILABLE

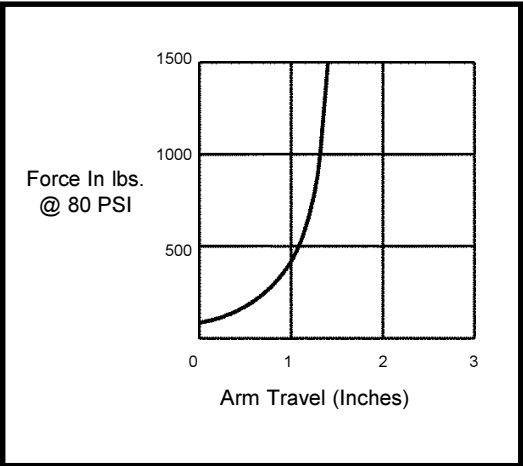
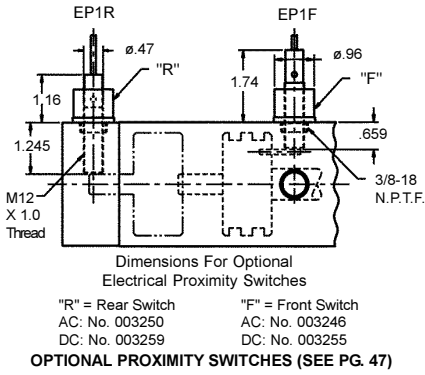
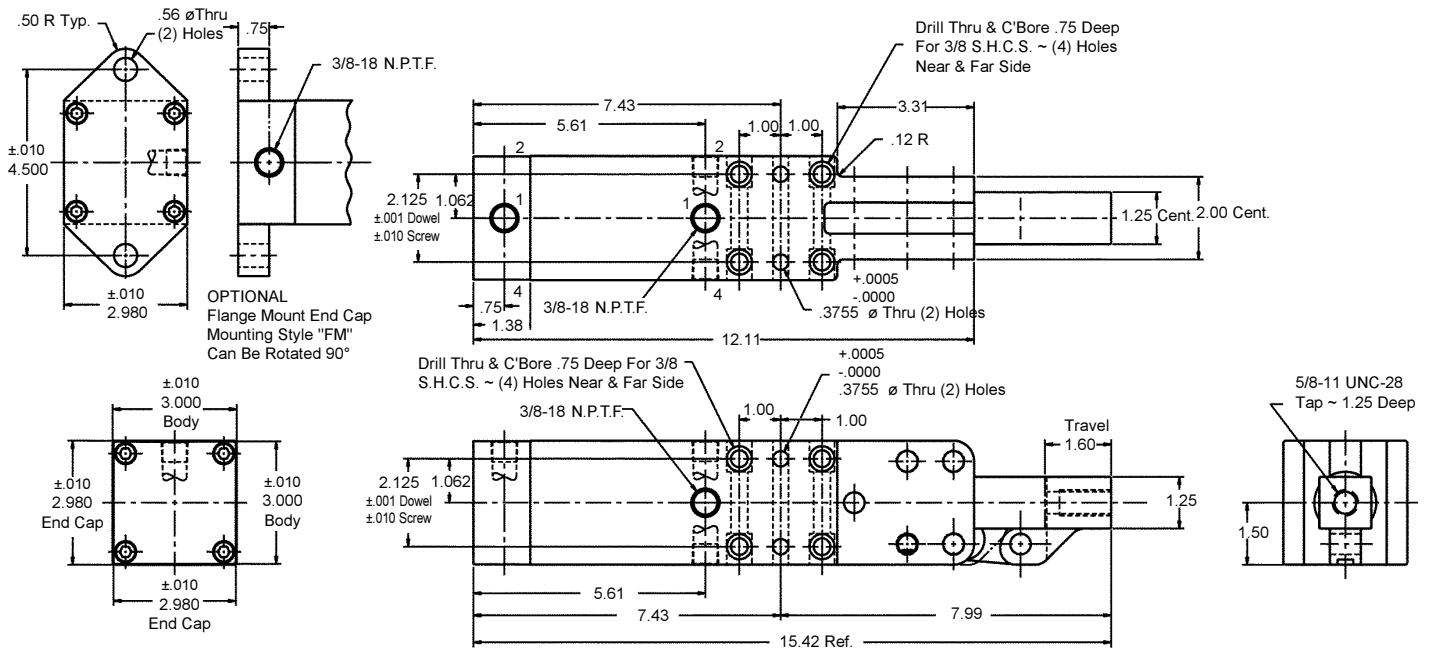

SPECIFICATIONS
 Bore ø: 2.5"
 Stroke: 2.154"
 Arm Opening: 1.6"
 Recommended operating pressure: 80 - 100 PSI
 Use Flow controls to reduce impact
 Approx. Weight: 11 lbs.

BTM CORPORATION
 Manufactured by BTM CORPORATION
 Marysville, Michigan USA
 PATENTED

HOW TO ORDER

- POWER CLAMP
- 2500 SERIES: 2.5" BORE
- ARM OPENING: LINEAR 1.6"
- MOUNTING STYLE: FM FLANGE MOUNT
- FRONT PORT POSITION: FP1, FP2, FP3, FP4
- REAR PORT POSITION: RP1, RP2, RP3, RP4
- FRONT PROX. POSITION: EP1F, EP2F, EP3F, EP4F
- REAR PROX. POSITION: EP1R, EP2R, EP3R, EP4R
- SWITCH TYPE: AC OR DC

BTM PC-2500-PL 1.6 -FM -FP4 -RP1 -EP2F -EP3R -AC

Body Mount No. 012509 OPTIONS
 Flange Mount No. 012510

CAD TEMPLATES AVAILABLE

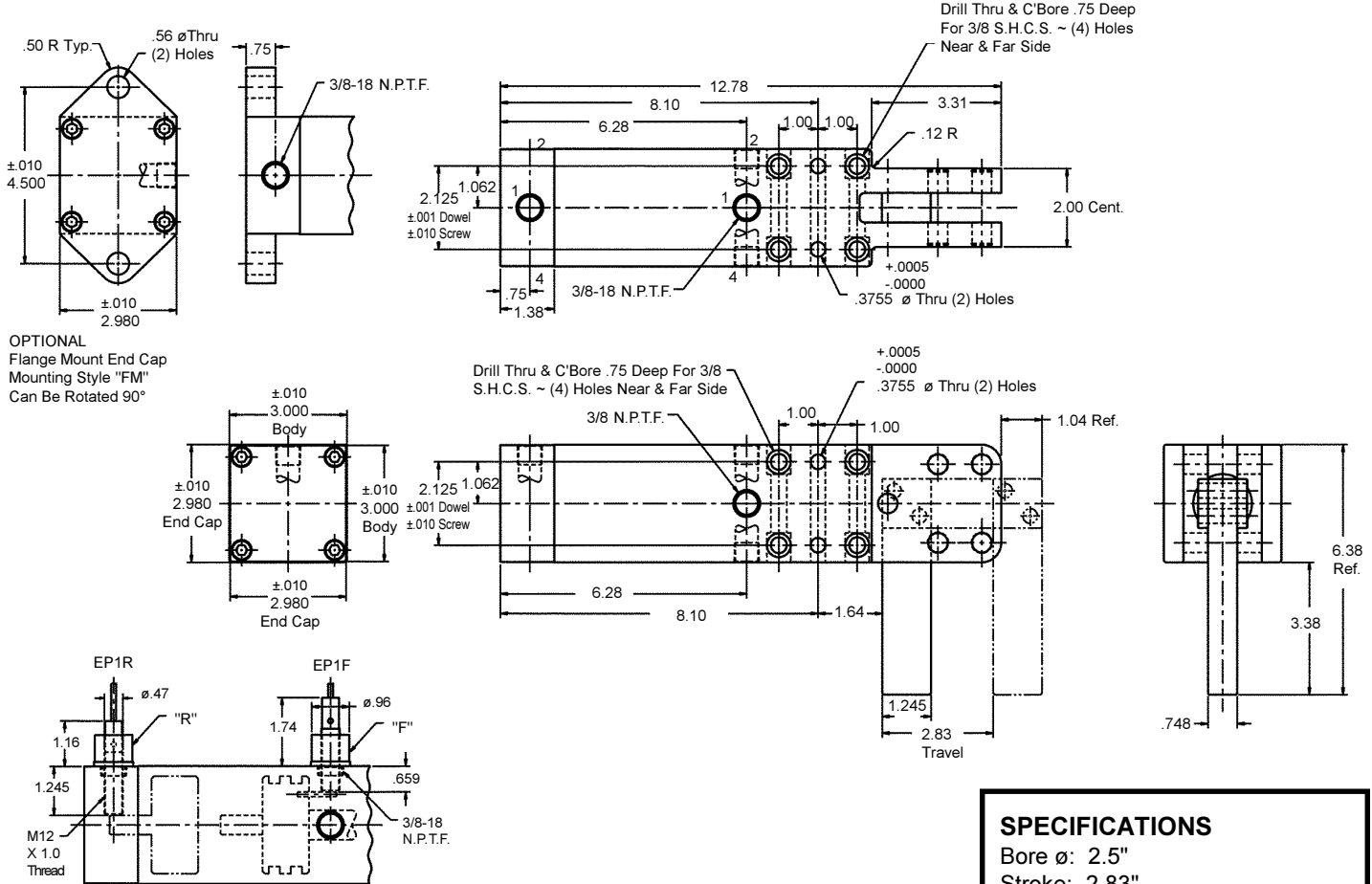

OPTIONAL Flange Mount End Cap Mounting Style "FM" Can Be Rotated 90°

Dimensions For Optional Electrical Proximity Switches

"R" = Rear Switch "F" = Front Switch
 AC: No. 003250 AC: No. 003246
 DC: No. 003259 DC: No. 003255

OPTIONAL PROXIMITY SWITCHES (SEE PG. 47)

SPECIFICATIONS

- Bore ø: 2.5"
- Stroke: 2.83"
- Arm Opening: 2.83"
- Slide Clamp = No Toggle Action
- Recommended operating pressure: 80 - 100 PSI
- Use Flow controls to reduce impact
- Approx. Weight: 11 lbs.



Manufactured by
 BTM CORPORATION
 Marysville, Michigan USA
 PATENTED

HOW TO ORDER

CLAMP FORCE (lbs) = 4 X LINE PRESSURE (P.S.I.)

POWER CLAMP

2500 SERIES: 2.5" BORE

ARM OPENING: LINEAR 2.8"

FLANGE MOUNT

FRONT PORT POSITION: FP1, FP2, FP3, FP4

REAR PORT POSITION: RP1, RP2, RP3, RP4

FRONT PROX. POSITION: EP1F, EP2F, EP3F, EP4F

REAR PROX. POSITION: EP1R, EP2R, EP3R, EP4R

SWITCH TYPE: AC OR DC

BTM PC-2500-SL 2.8 -FM -FP4 -RP1 -EP2F -EP3R -AC

Body Mount No. 001437
 Flange Mount No. 012516

OPTIONS



Omni-Head Power Toggle Clamps

PCO 100 Series • PCO 1500 Series

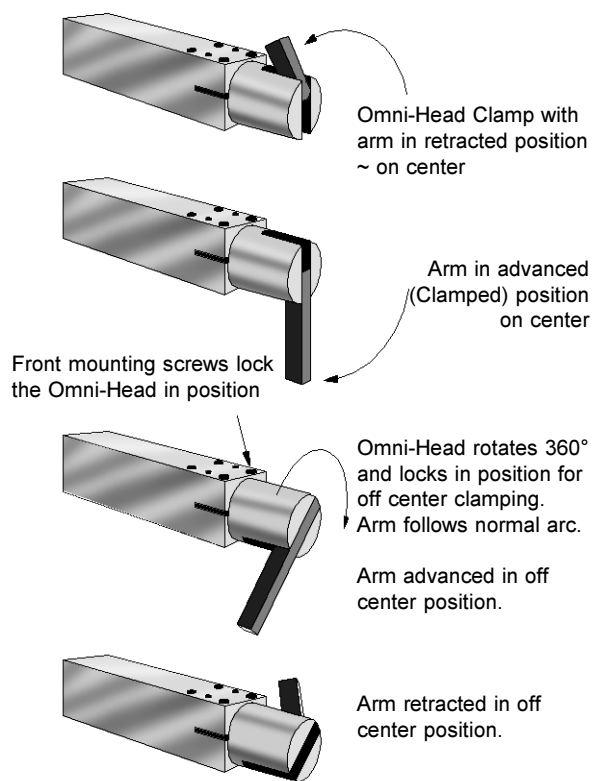

FEATURES

- Gripper head rotates 360° & locks in position for off center gripping.
- Hardcoated aircraft aluminum body.
- Optional pre-fitted proximity switches.
- Positive Locking Toggle Action
- Light weight.

CAD TEMPLATES AVAILABLE

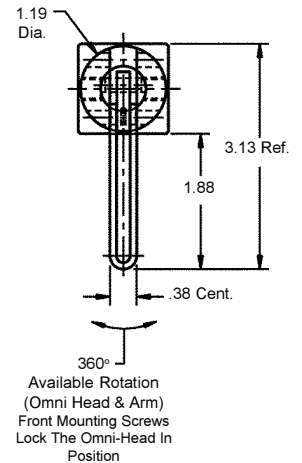
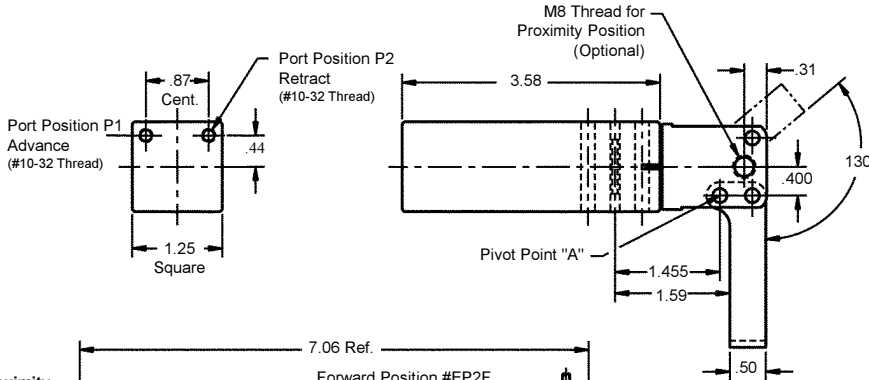
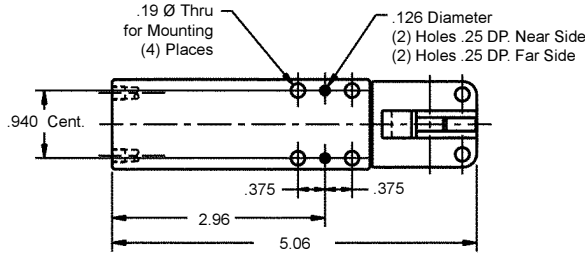

See Pg. 47 For Proximity Switches

Note: For special proximity sensing or alterations, please call BTM Corporation for a quote.

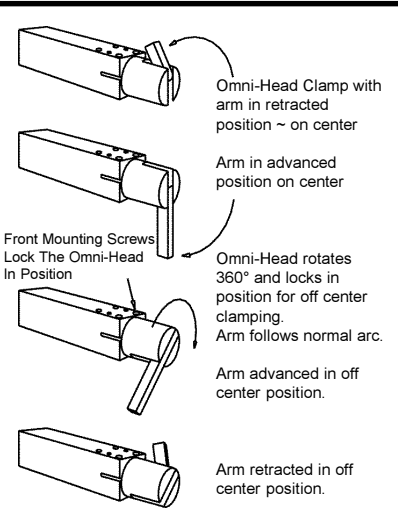
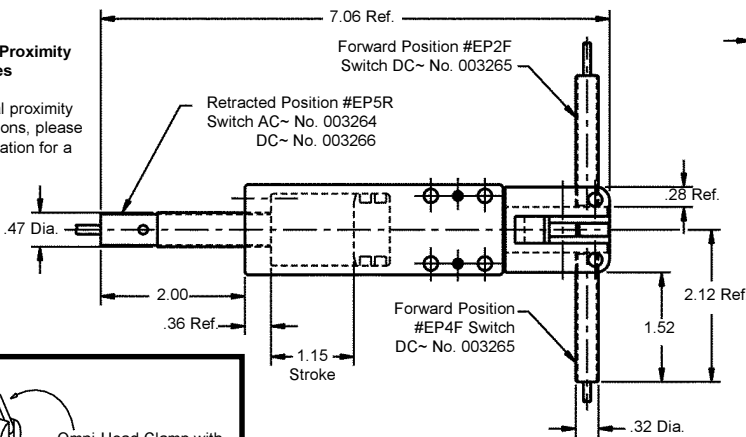

$$\text{CLAMP FORCE (lbs)} = \frac{.5 \times \text{LINE PRESSURE (P.S.I.)} \times \text{LENGTH FROM POINT "A" TO CENTER LINE OF GRIPPING CONTACT AREA ON GRIPPER ARM (INCHES)}}{1}$$

SPECIFICATIONS

- Bore \varnothing : 1.00"
- Stroke: 1.15"
- Arm Opening: 130°
- Recommended operating pressure: 80 - 100 PSI
- Use Flow controls to reduce impact
- Approx. Weight: 12 OZ.



Manufactured by
BTM CORPORATION
Marysville, Michigan USA
PATENTED

HOW TO ORDER

- POWER CLAMP OMNI (PCO)
- 100 SERIES: 1.00 Bore
- ARM OPENING: VERTICAL 130°
- FRONT ELECTRIC PROXIMITY POSITION: EP2F, EP4F
- SWITCH TYPE: DC ONLY
- REAR ELECTRICAL PROXIMITY POSITION: EP5R
- SWITCH TYPE: AC OR DC

BTM PCO-100-V130 - EP2F-DC-EP5R-AC

BTM No. 002767

OPTIONS

100 Series Omni Clamp PCO-100-H 110



CAD TEMPLATES AVAILABLE

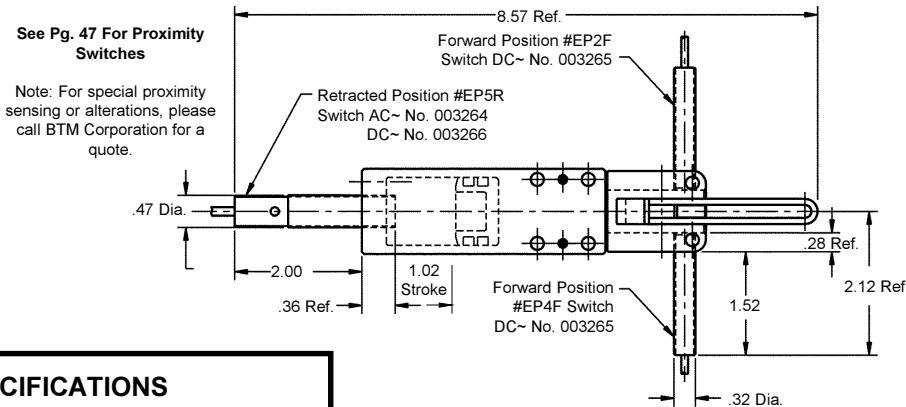
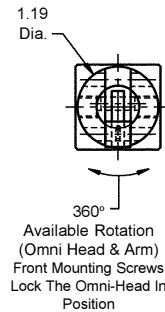
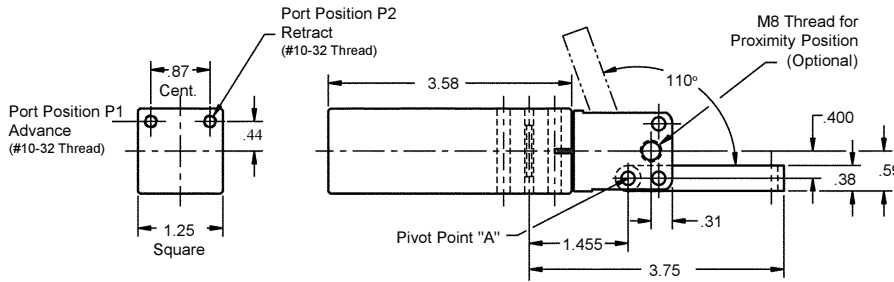
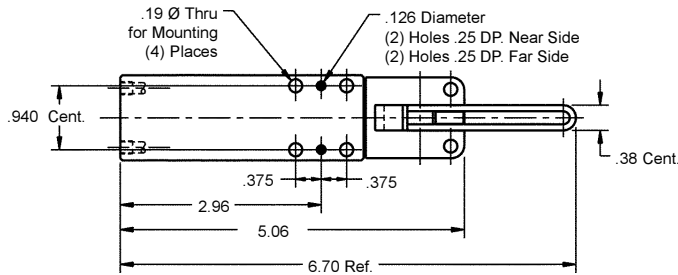

See Pg. 47 For Proximity Switches

Note: For special proximity sensing or alterations, please call BTM Corporation for a quote.

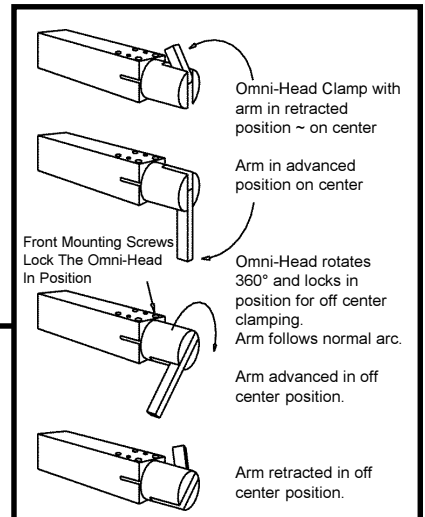

SPECIFICATIONS

Bore ø: 1.00"
Stroke: 1.02"
Arm Opening: 110°
Recommended operating pressure: 80 - 100 PSI
Use Flow controls to reduce impact
Approx. Weight: 12 OZ.

$$\text{CLAMP FORCE (lbs)} = \frac{.5 \times \text{LINE PRESSURE (P.S.I.)}}{\text{LENGTH FROM POINT "A" TO CENTER LINE OF GRIPPING CONTACT AREA ON GRIPPER ARM (INCHES)}}$$



Manufactured by
BTM CORPORATION
Marysville, Michigan USA
PATENTED

HOW TO ORDER

POWER CLAMP OMNI (PCO)
100 SERIES: 1.00 BORE
ARM OPENING: HORIZONTAL 110°
FRONT ELECTRICAL PROXIMITY POSITION: EP2F, EP4F
SWITCH TYPE: DC ONLY
REAR ELECTRICAL PROXIMITY POSITION: EP5R
SWITCH TYPE: AC OR DC

BTM PCO-100-H110 - EP2F-DC-EP5R-AC

BTM No. 002857

OPTIONS



100 Series Omni Clamp

PCO-100-SL 1.2

CAD TEMPLATES AVAILABLE

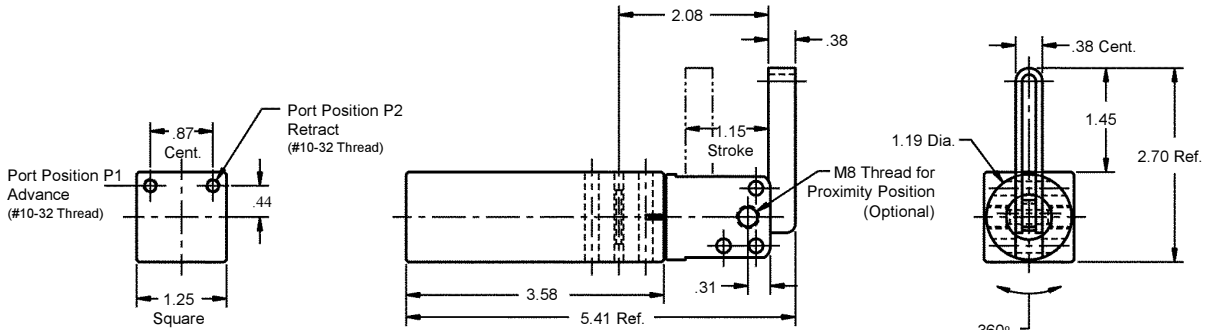
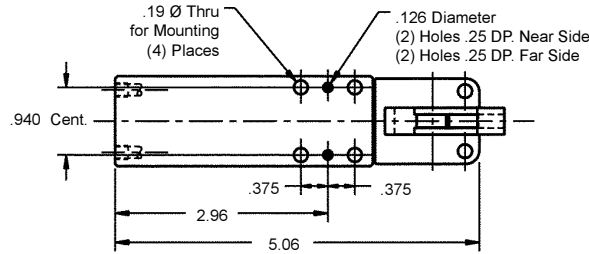

360°
Available Rotation
(Omni Head & Arm)
Front Mounting Screws
Lock The Omni-Head In
Position

See Pg. 47 For Proximity
Switches

Note: For special proximity
sensing or alterations, please
call BTM Corporation for a
quote.

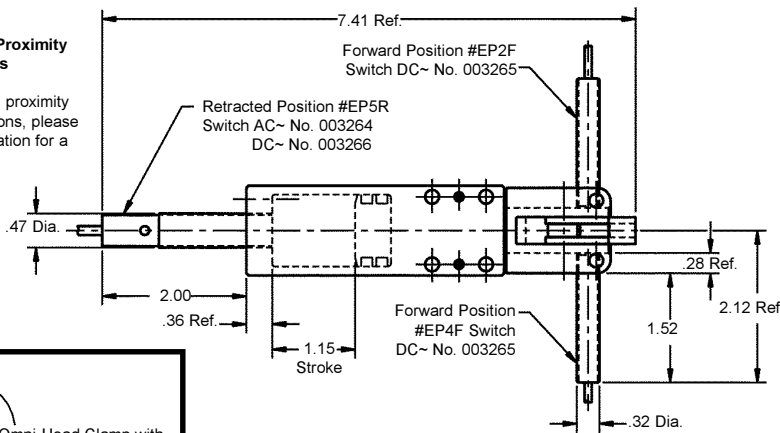

SPECIFICATIONS

Bore \varnothing : 1.00"
Stroke: 1.15"
Arm Opening: 1.15"
Recommended operating pressure:
80 - 100 PSI
Use Flow controls to reduce impact
Approx. Weight: 12 OZ.



Manufactured by
BTM CORPORATION
Marysville, Michigan USA
PATENTED

$$\text{CLAMP FORCE (lbs)} = \frac{.67 \times \text{LINE PRESSURE (P.S.I.)}}{\text{LENGTH FROM POINT "A" TO CENTER LINE OF GRIPPING CONTACT AREA ON GRIPPER ARM (INCHES)}}$$

HOW TO ORDER

POWER CLAMP OMNI (PCO)
100 SERIES: 1.00 Bore
ARM OPENING: LINEAR 1.15"
FRONT ELECTRIC PROXIMITY POSITION: EP2F, EP4F
SWITCH TYPE: DC ONLY
REAR ELECTRICAL PROXIMITY POSITION: EP5R
SWITCH TYPE: AC OR DC

BTM PCO-100-SL1.2 - EP2F-DC-EP5R-AC

BTM No. 002860

OPTIONS

1500 Series Omni Clamp PCO-1500-V 130



CAD TEMPLATES AVAILABLE

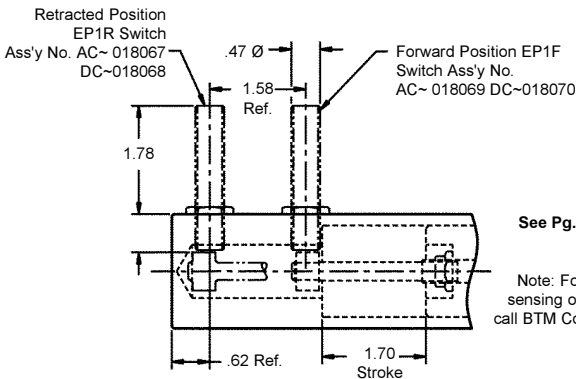
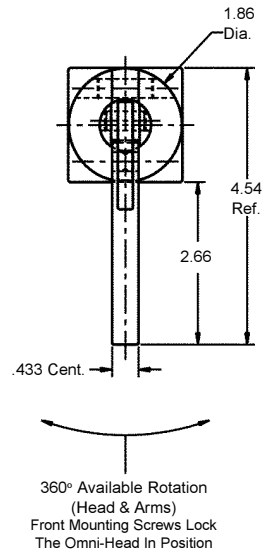
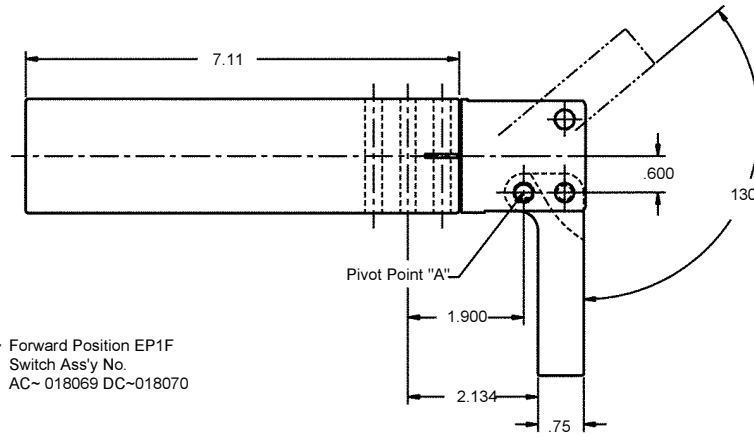
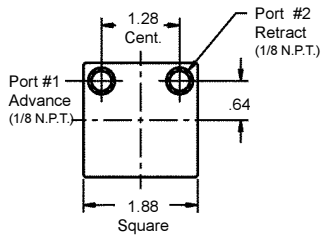
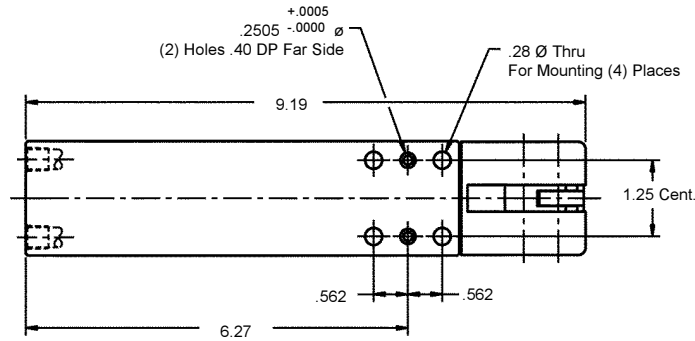

See Pg. 47 For Proximity Switches

Note: For special proximity sensing or alterations, please call BTM Corporation for a quote.

SPECIFICATIONS

Bore \varnothing : 1.50"
 Stroke: 1.70"
 Arm Opening: 130°
 Recommended operating pressure: 80 - 100 PSI
 Use Flow controls to reduce impact
 Approx. Weight: 3 lbs.

$$\text{CLAMP FORCE (lbs)} = \frac{4 \times \text{LINE PRESSURE (P.S.I.)}}{\text{LENGTH FROM POINT "A" TO CENTER LINE OF GRIPPING CONTACT AREA ON GRIPPER ARM (INCHES)}}$$

HOW TO ORDER

POWER CLAMP OMNI (PCO)
 1500 SERIES: 1.50 BORE
 ARM OPENING: VERTICAL 130°
 FRONT ELECTRICAL PROXIMITY POSITION: EP2F, EP4F
 SWITCH TYPE: DC ONLY
 REAR ELECTRICAL PROXIMITY POSITION: EP5R
 SWITCH TYPE: AC OR DC



Manufactured by
 BTM CORPORATION
 Marysville, Michigan USA
 PATENTED

BTM PCO-1500-V130 - EP2F-DC-EP5R-AC

BTM No. 003404

OPTIONS



1500 Series Omni Clamp PCO-1500-H 110

CAD TEMPLATES AVAILABLE

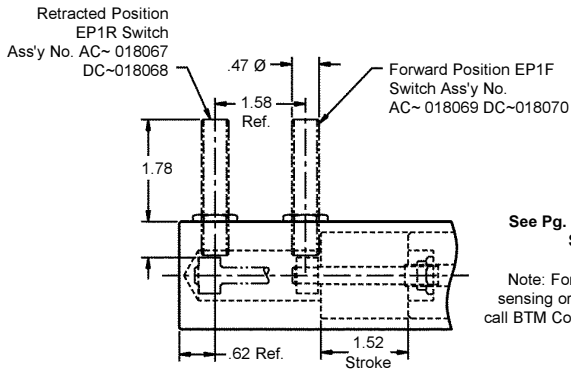
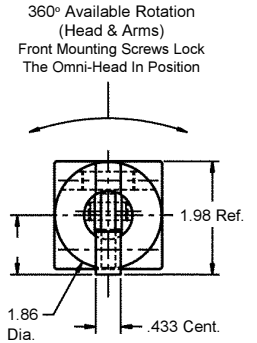
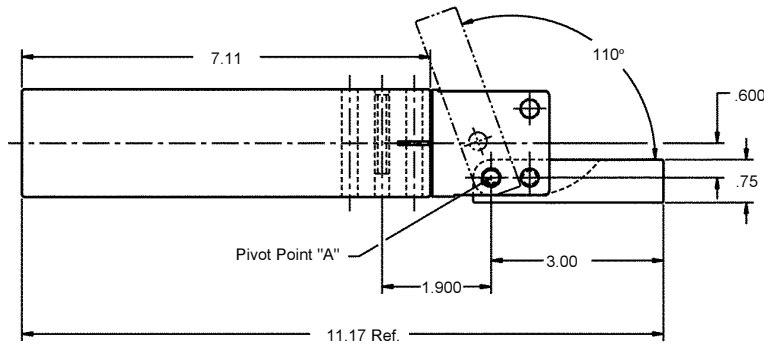
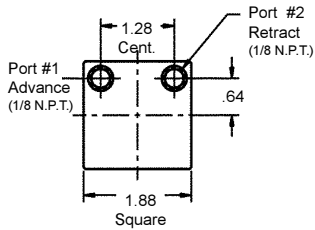
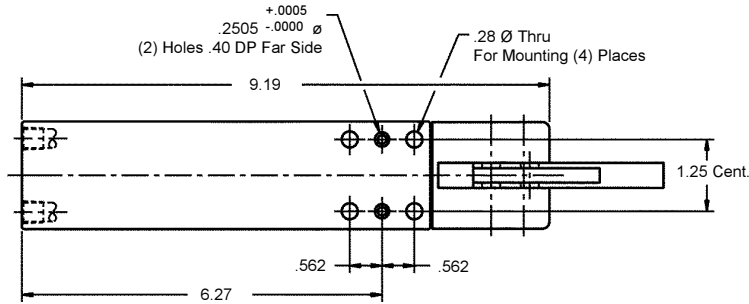

See Pg. 47 For Proximity Switches

Note: For special proximity sensing or alterations, please call BTM Corporation for a quote.

SPECIFICATIONS

Bore ϕ : 1.50"
Stroke: 1.52"
Arm Opening: 110°
Recommended operating pressure: 80 - 100 PSI
Use Flow controls to reduce impact
Approx. Weight: 3 lbs.



Manufactured by
BTM CORPORATION
Marysville, Michigan USA
PATENTED

$$\text{CLAMP FORCE (lbs)} = \frac{4 \times \text{LINE PRESSURE (P.S.I.)}}{\text{LENGTH FROM POINT "A" TO CENTER LINE OF GRIPPING CONTACT AREA ON GRIPPER ARM (INCHES)}}$$

HOW TO ORDER

POWER CLAMP OMNI (PCO)

1500 SERIES: 1.50 BORE

ARM OPENING: HORIZONTAL 110°

FRONT ELECTRIC PROXIMITY POSITION: EP2F, EP4F

SWITCH TYPE: DC ONLY

REAR ELECTRICAL PROXIMITY POSITION: EP5R

SWITCH TYPE: AC OR DC

BTM PCO-1500-H110 - EP2F-DC-EP5R-AC

BTM No. 017548

OPTIONS

1500 Series Omni Clamp

PCO-1500-SL 1.7



CAD TEMPLATES AVAILABLE

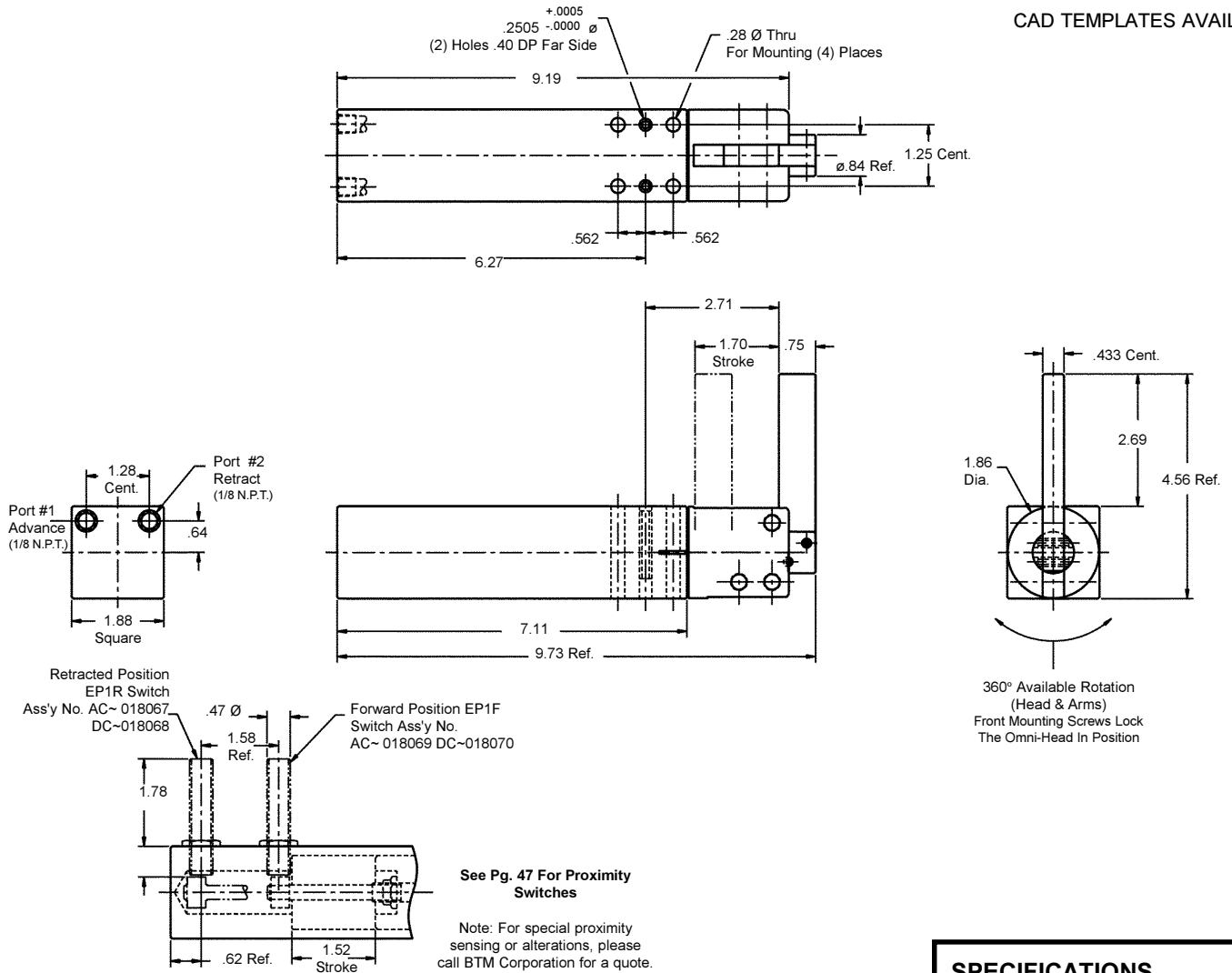

SPECIFICATIONS

Bore ϕ : 1.50"
 Stroke: 1.70"
 Arm Opening: 1.70"
 Recommended operating pressure: 80 - 100 PSI
 Use Flow controls to reduce impact
 Approx. Weight: 3 lbs.



Manufactured by
 BTM CORPORATION
 Marysville, Michigan USA
 PATENTED

$$\text{CLAMP FORCE (lbs)} = \frac{1.4 \times \text{LINE PRESSURE (P.S.I.)}}{\text{LENGTH FROM POINT "A" TO CENTER LINE OF GRIPPING CONTACT AREA ON GRIPPER ARM (INCHES)}}$$

HOW TO ORDER

POWER CLAMP OMNI (PCO)
 1500 SERIES: 1.50 BORE
 ARM OPENING: LINEAR 1.7"
 FRONT ELECTRIC PROXIMITY POSITION: EP2F, EP4F
 SWITCH TYPE: DC ONLY
 REAR ELECTRICAL PROXIMITY POSITION: EP5R
 SWITCH TYPE: AC OR DC

BTM PCO-1500-SL1.7 - EP2F-DC-EP5R-AC

BTM No. 017549

OPTIONS



1500 Series Retracting Power Clamp RPC-1500-V

RPC 1500V ~ BTM No. 738700A

Patents Applied For



Allows simplified part transfer, or to clamp in through hole applications. The clamp head retracts into the body for clearance when open. Features rotatable mounting to simplify installation.

BORE: 1.5" [38mm]

CLAMPING FORCE
210 lbs. [934 N] @ 80 psi [5.5 bars]

Weight 8.5 lbs. [3.9 Kg.]

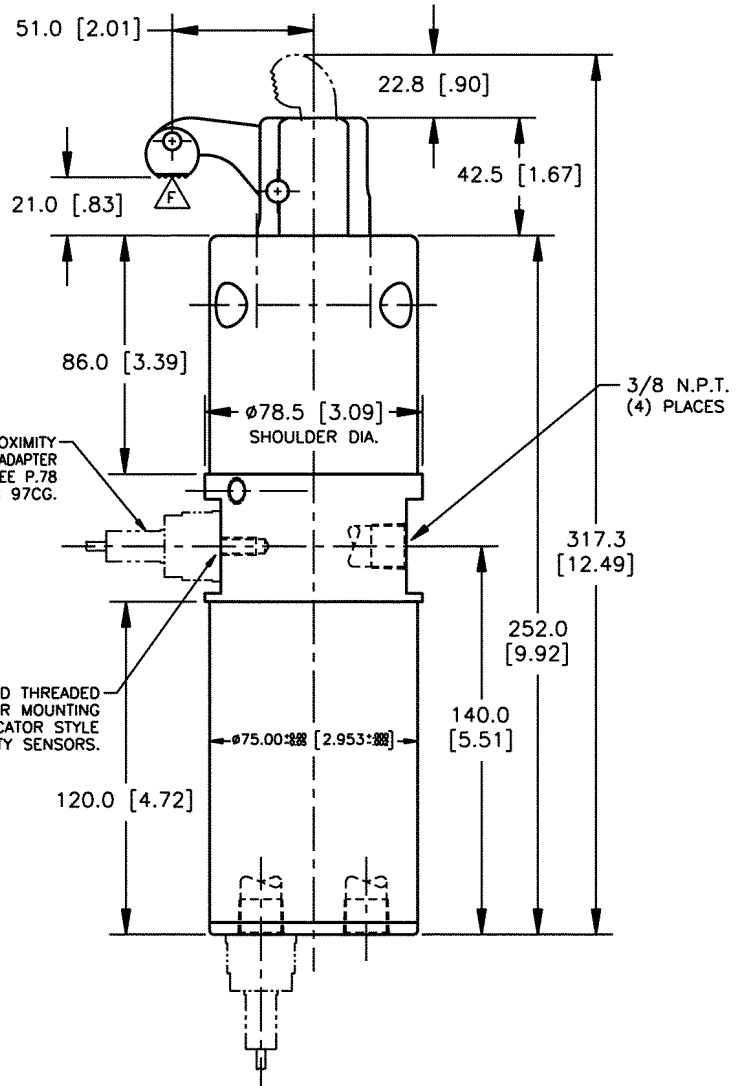
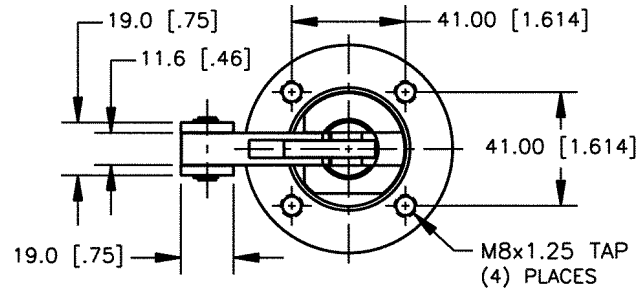
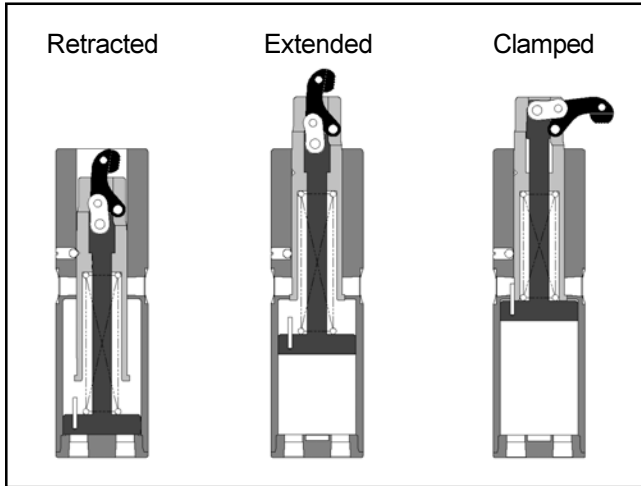

OPTIONAL PROXIMITY SWITCHES (See Pg. 47)

NAMCO LPR CYLINDRATOR:
LPR1 = EE230-10420 (MINI CONNECTOR)
LPR2 = EE230-10422 (MICRO CONNECTOR)

TURCK CRS CYLINDER POSITION INDICATOR:
CRS1 = Bi2-CRS-260-ADZ30X2-B1131/S34 (MINI CONNECTOR)
CRS2 = Bi2-CRS-260-ADZ30X2-B3131/S34 (MICRO CONNECTOR)

BTM PROXIMITY SWITCH W/ ADAPTER:
BES1 = BTM NO. 006266 (AC)
BES2 = BTM NO. 006463 (DC)

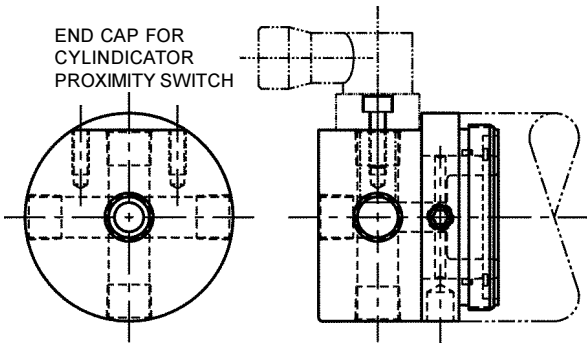

BTM PROXIMITY SWITCH W/ ADAPTER AC/DC - SEE P.78 CATALOG 97CG.

FLATS (AND THREADED HOLES) FOR MOUNTING CYLINDRATOR STYLE PROXIMITY SENSORS.

HOW TO ORDER

10 - RPC 1500V - 1 - 1 B - 2 BES1

Quantity	Model	Pad no.	Quantity Mount	Quantity Prox. Switch
10	RPC 1500V	- 1	1 B	2 BES1

1500 Series Retracting Power Clamp RPC-1500-V



Adjustable Mounts

Provide linear and rotational adjustment to simplify clamp mounting.

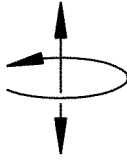

MOUNT "B"
Offset Mount No. 738400B

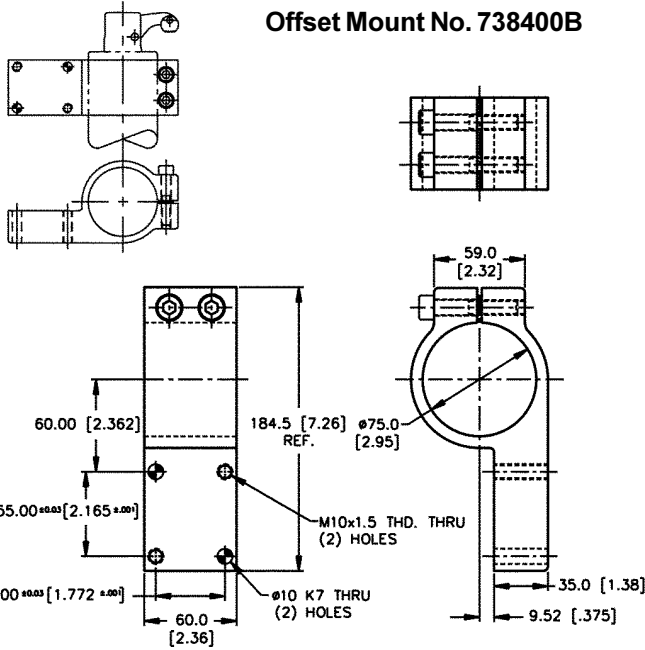

MOUNT "A"
On Center Mount
No. 738700C

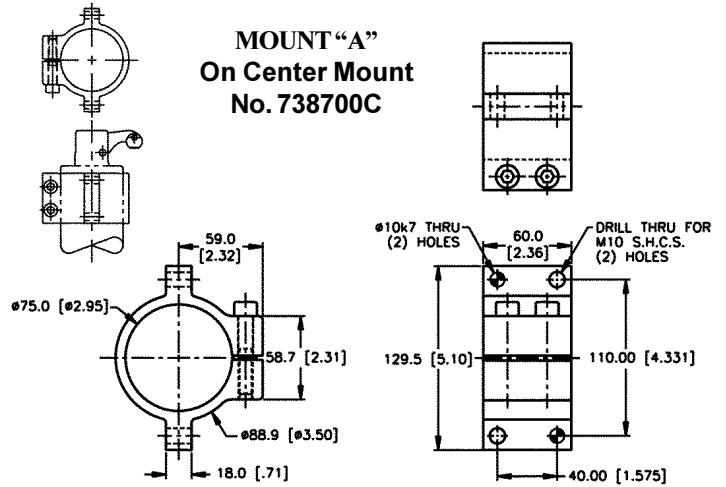

MOUNT "C"
Base Mount No. 738400C

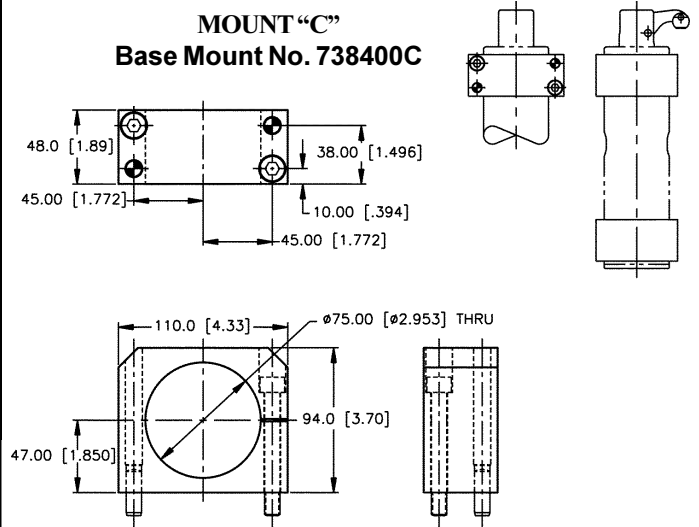

Interchangeable Clamp Pads



Steel Plain - #11



Steel Teeth - #1



Steel Cone Point - #5



Urethane
Soft #9/60
Hard #9/90

MOUNT "D"
90° Mount No. 738900B

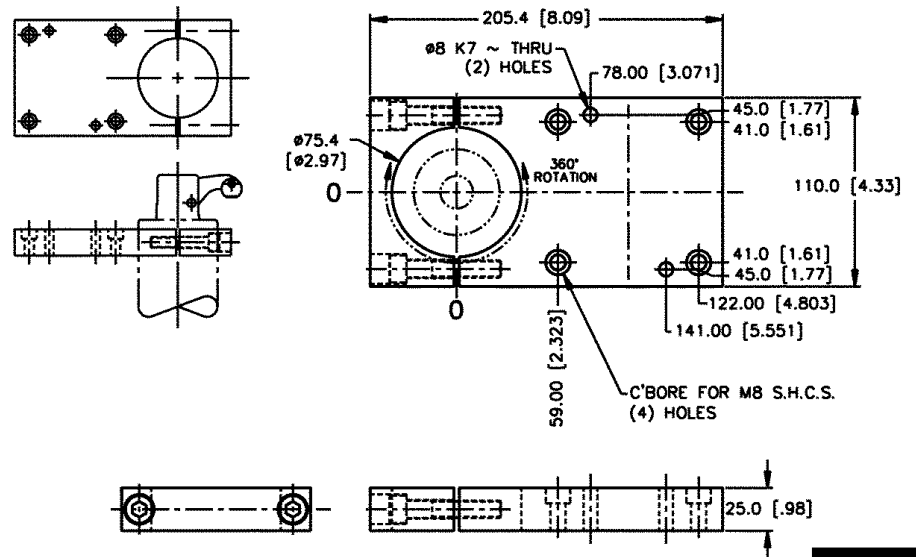

Rotary - Linear Power Clamps

RC 1500 Series • RC 2500 Series



90° Rotation with linear travel at both ends of the stroke. May be used in push or pull direction.

FEATURES

- 90° Clockwise or counter clockwise rotation.
- Linear travel at both ends of stroke.
- Harmonic motion.
- Sealed mechanism.
- Hardcoated aircraft aluminum body.
- Optional pre-fitted proximity switches.
- Light weight.



1500 Series Rotary Linear Clamp

15-90 CWR / 15-90 CCR



CAD TEMPLATES AVAILABLE

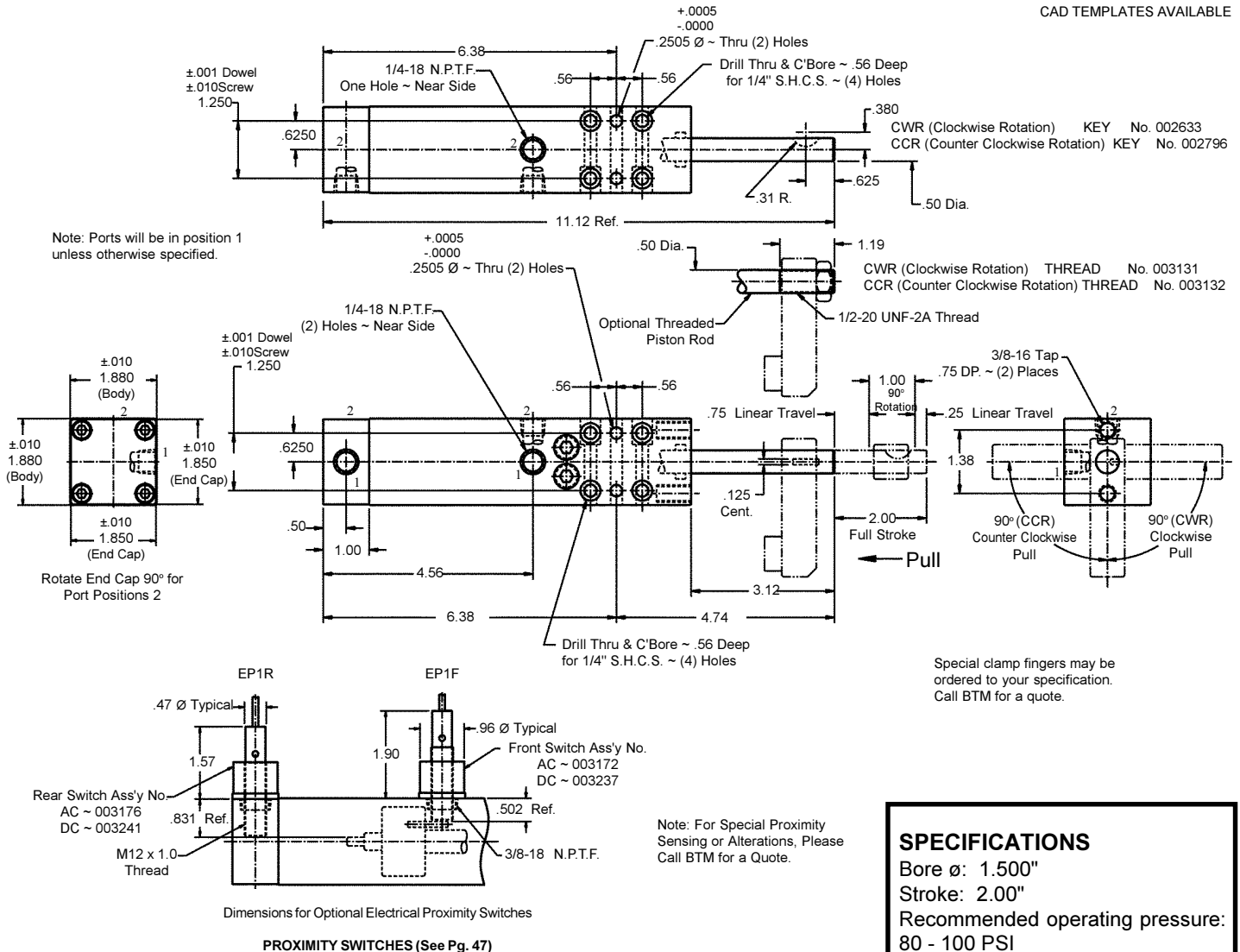

SPECIFICATIONS
 Bore ø: 1.500"
 Stroke: 2.00"
 Recommended operating pressure:
 80 - 100 PSI
 Use Flow controls to reduce impact
 Approx. Weight: 3 lbs.

BTM Patented
 Manufactured by BTM CORPORATION
 Marysville, Michigan USA

CLAMP FORCE (lbs) = 1.4 x Line Pressure (P.S.I.)

HOW TO ORDER

- ROTARY CLAMP
- 1500 SERIES
- ARM ROTATION 90°
- ROTATION (CWR KEY, CWR THREAD, CCR KEY, CCR THREAD)
- FRONT PORT : FP1, FP2
- REAR PORT : RP1, RP2
- FRONT ELEC. PROX. POSITION : EP1F, EP2F
- REAR ELEC. PROX. POSITION : EP1R, EP2R
- SWITCH TYPE : AC OR DC

BTM RC-1500-90-CWR KEY **FP2-RP2-EP2F-EP2R-AC**
 BTM No. 002633 **OPTIONS**



2500 Series Rotary Linear Clamp

25-90 CWR / 25-90 CCR

CAD TEMPLATES AVAILABLE

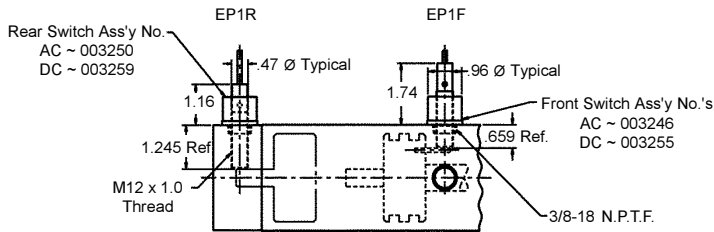
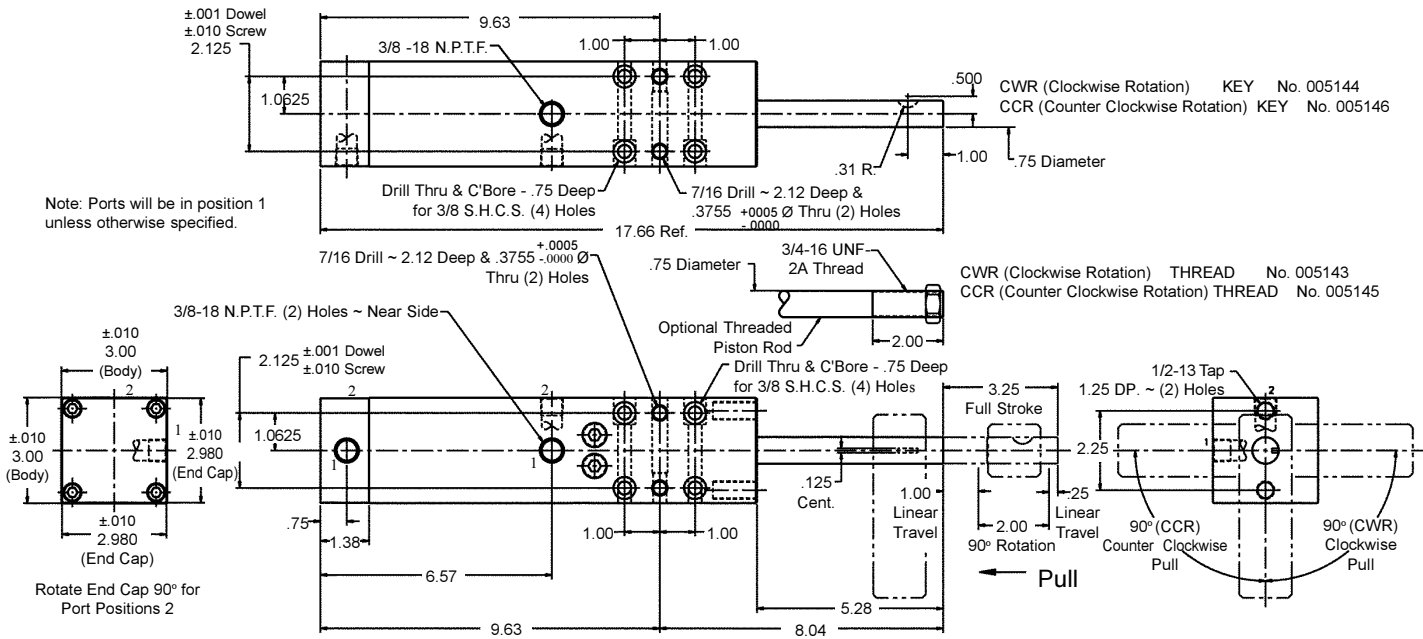

Dimensions for Optional Electrical Proximity Switches

PROXIMITY SWITCHES (See Pg. 47)

Note: For Special Proximity Sensing or Alterations, Please Call BTM for a Quote.

Special clamp fingers may be ordered to your specification. Call BTM for a quote.

SPECIFICATIONS

Bore ø: 2.500"
Stroke: 3.25"
Recommended operating pressure: 80 - 100 PSI
Use Flow controls to reduce impact
Approx. Weight: 11 lbs.



Manufactured by
BTM CORPORATION
Marysville, Michigan USA
PATENTED

CLAMP FORCE (lbs) = 4 x Line Pressure (P.S.I.)

HOW TO ORDER

ROTARY CLAMP

1500 SERIES

ARM ROTATION 90°

ROTATION (CWR KEY, CWR THREAD, CCR KEY, CCR THREAD)

FRONT PORT : FP1, FP2

REAR PORT : RP1, RP2

FRONT ELEC. PROX. POSITION : EP1F, EP2F

REAR ELEC. PROX. POSITION : EP1R, EP2R

SWITCH TYPE : AC OR DC

BTM RC-2500-90-CWR KEY

FP2-RP2-EP2F-EP2R-AC

BTM No. 005144

OPTIONS

Proximity Switches for 100, 1500 & 2500 Series Clamps



SERIES	EP1R	EP2R	EP3R	EP4R	EP5R	EP1F	EP2F	EP3F	EP4F	SPECIFICATIONS
50	006266	006266	006266	006266	006266*	006266	006266	006266	006266	AC ~ Normally Open (12mm) Supply Voltage: 20-250 VAC Load Current Max.: 5-30mA Supplied w/ 3 meter - 2 wire cable.
63	006266	006266	006266	006266	006266	006266	006266	006266	006266	
1500	003176	003176	003176	003176	003176	003176	003176	003176	003176	
2500	003250	003250	003250	003250	003250	003250	003250	003250	003250	
100 Omni	N/A	N/A	N/A	N/A	N/A	N/A	N/A	N/A	N/A	
1500 Omni	018067	N/A	N/A	N/A	018067	018067	N/A	N/A	N/A	
15-90	003176	003176	003176	003176	003176	003176	003176	003176	003176	
25-90	003250	003250	003250	003250	003250	003250	003250	003250	003250	
PPL	006266	006266	006266	006266	006266	006266	006266	006266	006266	
50	006463	006463	006463	006463	006463*	006463	006463	006463	006463	
63	006463	006463	006463	006463	006463	006463	006463	006463	006463	
1500	003241	003241	003241	003241	003241	003237	003237	003237	003237	
2500	003259	003259	003259	003259	003259	003255	003255	003255	003255	
100 Omni	N/A	N/A	N/A	N/A	003266	N/A	N/A	N/A	N/A	
1500 Omni	018068	NA	NA	NA	NA	018069	N/A	N/A	N/A	
15-90	003241	003241	003241	003241	003241	003237	003237	003237	003237	
25-90	003259	003259	003259	003259	003259	003255	003255	003255	003255	
PPL	006463	006463	006463	006463	006463	006363	006363	006363	006363	
100 Omni	N/A	N/A	N/A	N/A	N/A	N/A	003265	N/A	003265	DC ~ Normally Open (8mm) Sourcing Supply Voltage: 10-30 VDC Load Current Max.: ≤200mA Supplied w/ 3 meter - 3 wire cable.

100, 1500 & 2500 Series Clamp Arm Spindles

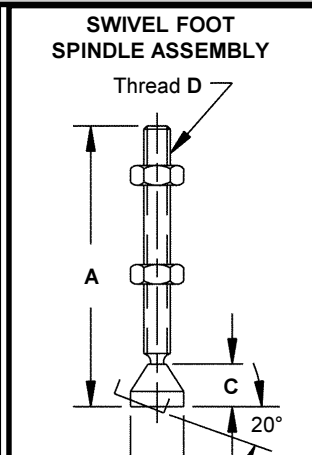
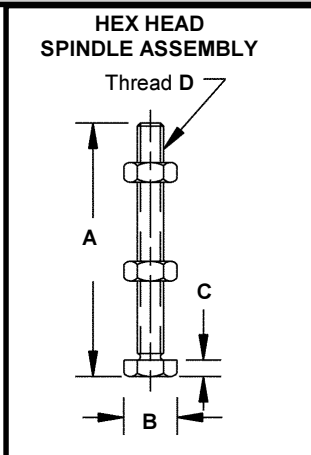
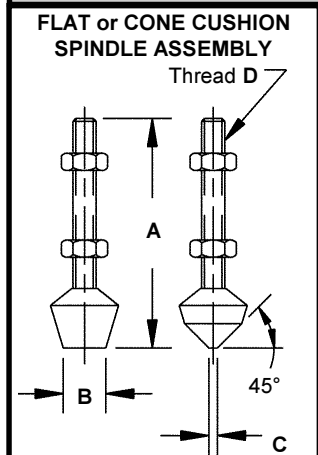
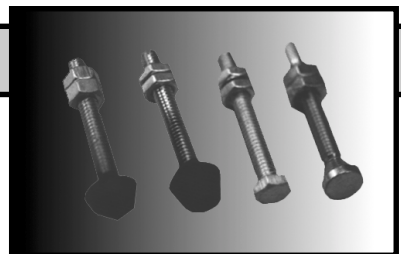

FIELD MOUNTING DIMENSIONS for 1500 & 2500 SPINDLE ASS'YS.

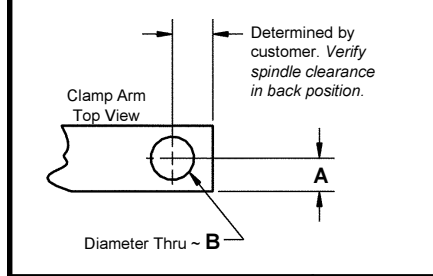

	A	B
1500 SERIES	.22" 5.6mm	.28" 7.1mm
2500 SERIES	.38" 9.6mm	.41" 10.4mm

100 SERIES
Flat ~ 012605 / Cone ~ 012606

A	B	C	D
1.38" 35.0mm	.44" 11.2mm	.16" 4.1mm	#10-32

100 SERIES
012611

A	B	C	D
1.38" 35.0mm	.31" 7.9mm	.12" 3.0mm	#10-32

1500 SERIES
012615

A	B	C	D
2.25" 57.2mm	.50" 12.7mm	.36" 9.6mm	1/4-20

1500 SERIES
Flat ~ 012607 / Cone ~ 012608

A	B	C	D
2.44" 62.0mm	.38" 9.6mm	.06" 1.5mm	1/4-20

1500 SERIES
012612

A	B	C	D
2.12" 53.8mm	.50" 12.7mm	.16" 4.1mm	1/4-20

2500 SERIES
012616

A	B	C	D
3.50" 88.9mm	.62" 15.7mm	.50" 12.7mm	3/8-16

2500 SERIES
Flat ~ 012609 / Cone ~ 012610

A	B	C	D
3.50" 88.9mm	.56" 14.2mm	.06" 1.5mm	3/8-16

2500 SERIES
012613

A	B	C	D
3.75" 95.2mm	.62" 15.7mm	.25" 6.4mm	3/8-16

2500 SERIES
012616

A	B	C	D
3.50" 88.9mm	.62" 15.7mm	.50" 12.7mm	3/8-16

FLANGED WASHER for 100 SERIES CLAMPS 012617