

PIN & HOOK CLAMPS

Reduce cost by clamping through holes, slots or along edges.

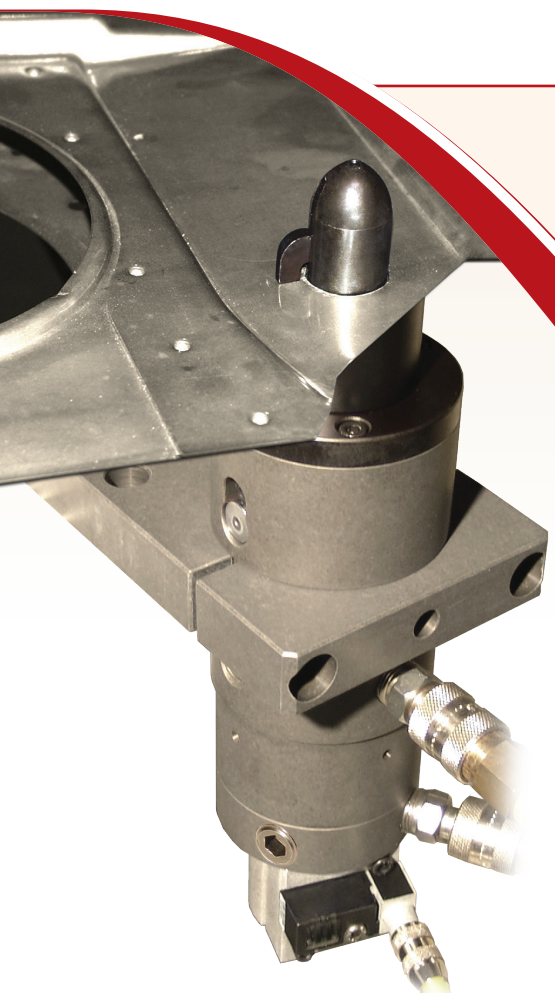

Pin Clamps locate, **AND** clamp through holes or slots



Hook Clamps offer reduced cost, simple clamping through holes, slots, or along edges



PLC25

PLC45

PLC63 (Shown)
SFC63

RLPC45
RLPC63 (Shown)
RLSFC63

LPLC-38 (Shown)
LPLC-38M
LSFC-38

See the BTM Pin & Hook Clamp Line of Products

<http://www.btmcomp.com/pin-and-hook-products.html>



www.btmcomp.com

810-364-4567



SAFETY NOTE

Customer is responsible for the safe operation and use of the products shown in this literature.

INTRODUCTION

BTM Pin Clamps reduce cost by both accurately locating through datum holes and clamping a part with one device. XYZ location register is achieved by incorporating a clamping finger or hook inside the locator pin thereby eliminating expensive swing arm power clamps.

The less expensive Hook Clamps are used when accurate part location is not required.

BTM Hook Clamps provide simple clamping through holes, slots or along edges further reducing cost. Hooked style fingers clamp over flanged holes.

Pin Clamps and Hook Clamps come in 3 types: **Clamping, Retaining, and Locking.**

Clamping – PLC and SFC – Air pressure on a piston multiplies the force required to clamp the part to the net surface.

Retaining – RLPC and RLFPC – Air pressure applies both clamping force and retracts a spring loaded rod locker, which upon loss of air engages the finger/hook to retain the clamped part. This light weight and compact clamp is best for material handling and robotic EOAT.

Locking – LPLC and LSFC – A patented air driven cam mechanism maintains clamp force upon removal of air making this clamp ideal for moving fixtures. Clamp force is available within the last 3mm of finger/hook travel making this clamp ideal for clamping multiple part thicknesses.

All BTM Pin and Hook clamps feature 90° positioning of the finger/hook to avoid part obstructions or weld spatter. Round body clamps feature full 360° positioning of the finger/hook.

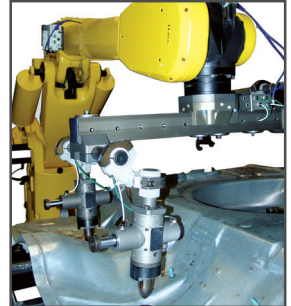
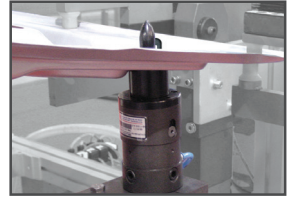

HOW THEY WORK

PIN CLAMPS (PLC, LPLC, RLPC)

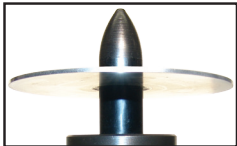

STEP ONE

With the clamp finger retracted, the part is loaded over the locating pin.



STEP TWO

The material rests on the clamp Rest Block ("Donut").

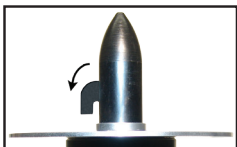

STEP THREE

The finger swings out of the locating pin with 5mm of rotational travel.

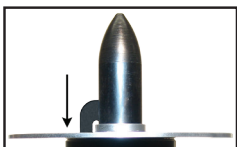

STEP FOUR

The finger has 10mm of straight travel. LPLCs clamp and lock in the last 3mm.

HOOK CLAMPS (SFC, LSFC, RLSFC)

STEP ONE

The part is loaded over the retracted finger and rests on the clamp rest block "donut".



STEP TWO

The finger swings in the direction of its clamping surface with 5mm of rotational travel.



STEP THREE

The finger has 10mm of straight travel. LSFCs clamp and lock in the last 3mm.



TABLE OF CONTENTS

NON-LOCKING MODELS



PLC25 Light Duty Pin Locating Clamp **4-5**

Hole/Slot Range	6mm-12.00mm
Clamping Force	231N @ 5.5BAR (52lbf @ 80PSI)

Features

- Compact & Light Weight
- 25mm bore pneumatic cylinder
- Magnetic Position Sensing Switch Option



PLC45 Pin Locating Clamp **6-7**

Hole/Slot Range	12.50mm-18.00mm
Clamping Force	578N @ 5.5BAR (130lbf @ 80PSI)

Features

- Clamps on top of a flange.



PLC63 Pin Locating Clamp **8-9**

Hole/Slot Range	18.00mm-40.00mm
Clamping Force	1334N @ 5.5BAR (300lbf @ 80PSI)

Features

- Finger relief for flanged hole clearance (25mm, 30mm, 40mm)



SFC63 Hook Clamp **10-11**

Hole/Slot Range	18.00mm-40.00mm
Clamping Force	1334N @ 5.5BAR (300lbf @ 80PSI)

Features

- A single clamp finger without a locating pin.

LOCKING MODELS



RLPC45 & 63 Rod-Locking Pin Locator Clamps **12-13**

	RLPC45	RLPC63
Hole/Slot Range	12.50mm-18.00mm	18.00mm-40.00mm
Clamping Force	578N @ 5.5BAR (130lbf @ 80PSI)	1334N @ 5.5BAR (300lbf @ 80PSI)

Features

- Retains the part when air pressure is removed or lost.
- Finger relief for flanged hole clearance (25mm, 30mm, 40mm)



RLSFC63 Rod-Locking Hook Clamp **14-15**

Hole/Slot Range	18.00mm-40.00mm
Clamping Force	1334N @ 5.5BAR (300lbf @ 80PSI)

Features

- Retains the part when air pressure is removed or lost.
- A single clamp finger without a locating pin.

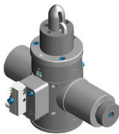

LPLC38 Locking Pin Locator Clamp **16-17**

Hole/Slot Range	18.00mm-40.00mm
Clamping Force	900 - 1334N @ 5.5BAR (200 - 300lbf @ 80PSI)

Features

- Maintains clamping force when locked, even if air pressure is removed or lost.
- Finger relief for flanged hole clearance (25mm, 30mm, 40mm)



LSFC38 Locking Hook Clamp **18-19**

Hole/Slot Range	18.00mm-40.00mm
Clamping Force	900 - 1334N @ 5.5BAR (200 - 300lbf @ 80PSI)

Features

- Maintains clamping force when locked, even if air pressure is removed or lost.
- A single clamp finger without a locating pin.

LPLC38M Manual Locking Pin Clamp **20-21**

Mounting Information **22**

Switch Information **23**

Warranty Information **Back Cover**

PLC25 LIGHT DUTY PIN CLAMP

A non-locking light duty pin locator clamp designed to clamp through small holes or slots.

Hole/Slot Size	6mm - 12mm
Clamping Force	222N @ 5.5BAR (50lbf @ 80PSI)
Finger Travel	6mm [0.24"] Total Consists of: <ul style="list-style-type: none"> • 3mm [0.12in] rotational • 3mm [0.12in] straight line pull down stroke
Bore Diameter	25.4mm [1.00in]
Cylinder Stroke	7.0mm [0.28in]
Recommended Operating Pressure	4.0 - 6.9 BAR [60 - 100 PSI]
Approximate Weight	0.28 kg [0.62 lbs] (depending on pin size)

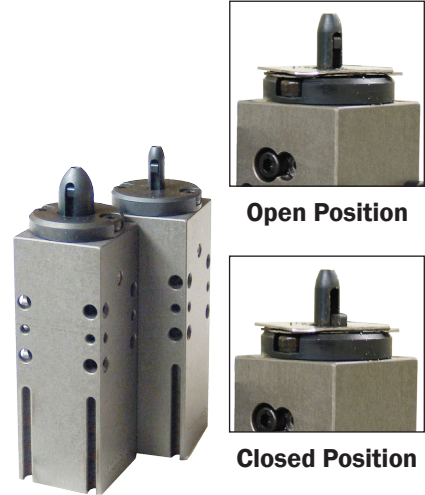

HOW TO ORDER

Call +1-810-364-4567, or email sales@btmcorp.com to request a quote!

CLAMP SELECTION	PIN SELECTION	SENSING	ASSEMBLY NUMBER										
PLC25	6.00	MPEDC	PD226300A										
CLAMP SERIES	PIN DIAMETER	SENSING OPTION	INCLUDE STANDARD BTM NUMBER OR SPECIAL NUMBER										
	<ul style="list-style-type: none"> 6.00 8.00 10.00 12.00 See p. 5 	<p>MPEDC = Efector DC Magnetic Position Sensing Switch (Note: 2 switches included & required)</p> <p>MPBDC = Balluf DC Magnetic Position Sensing Switch (Note: 2 switches included & required)</p> <p>NS = No Switch</p>	<table border="1"> <thead> <tr> <th>Pin Dia. (h7)</th> <th>BTM Number</th> </tr> </thead> <tbody> <tr> <td>6.00</td> <td>PD226300A</td> </tr> <tr> <td>8.00</td> <td>PD226500A</td> </tr> <tr> <td>10.00</td> <td>PD226700A</td> </tr> <tr> <td>12.00</td> <td>PD226900A</td> </tr> </tbody> </table>	Pin Dia. (h7)	BTM Number	6.00	PD226300A	8.00	PD226500A	10.00	PD226700A	12.00	PD226900A
Pin Dia. (h7)	BTM Number												
6.00	PD226300A												
8.00	PD226500A												
10.00	PD226700A												
12.00	PD226900A												

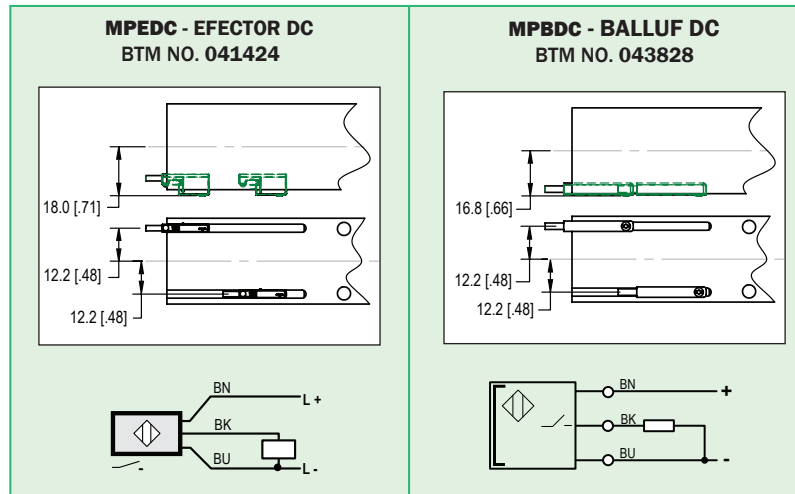

PLC25 LIGHT DUTY PIN CLAMP

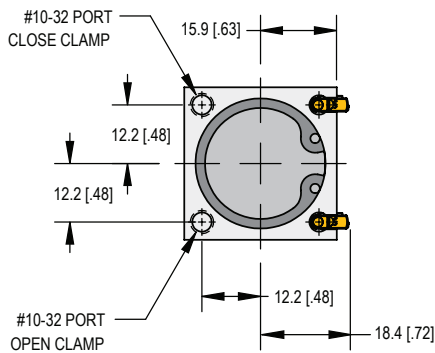
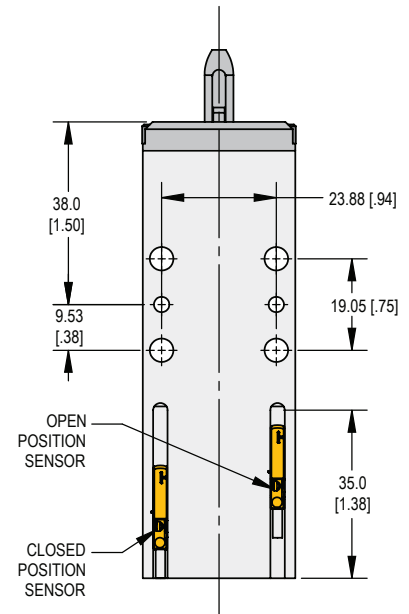
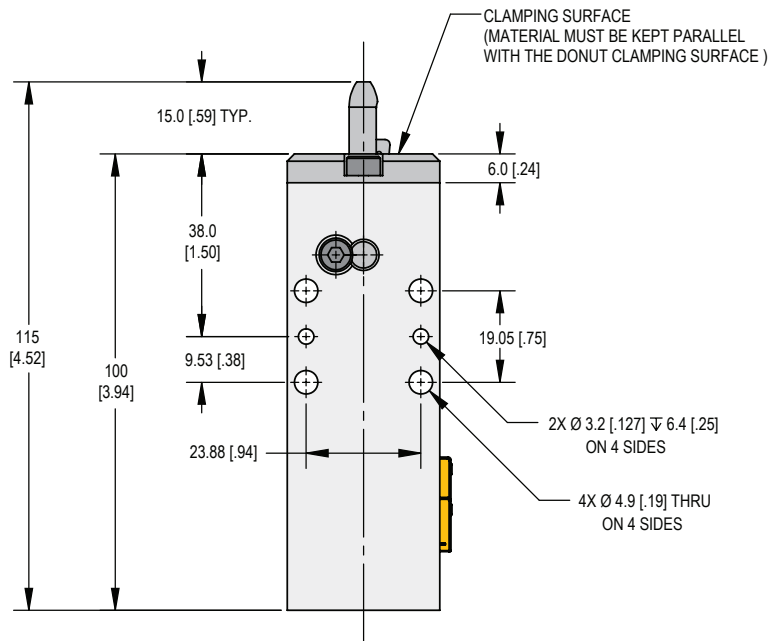
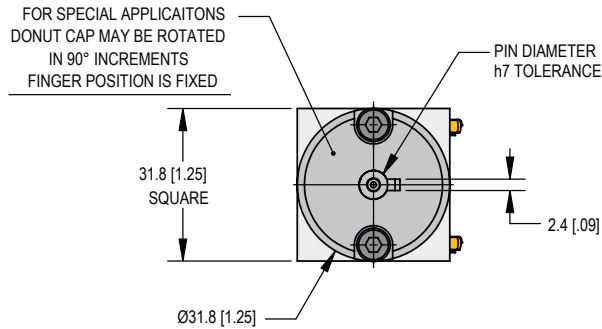

PIN DIAMETERS

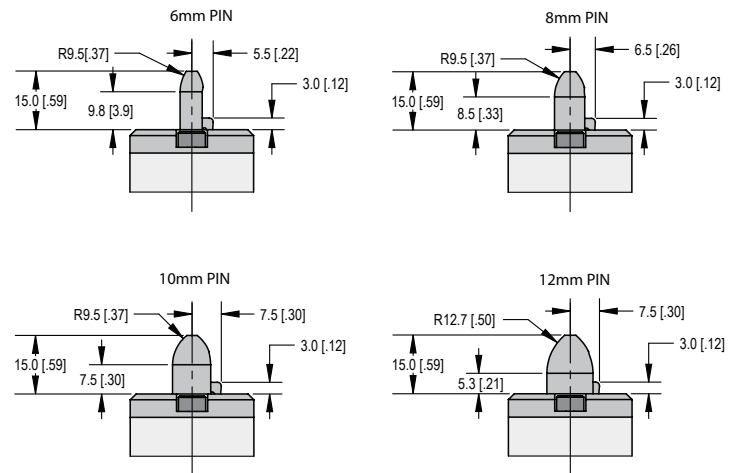

NOTE: BTM Pin Clamps can be ordered with custom designed (non-standard) pins, donuts, and/or fingers. In such instances, a SPECIAL OPTION number will be issued by BTM's Product Engineering Department. This number must be referenced when ordering a non-standard pin clamp.

PLC45 PIN CLAMP

A non-locking pin locator clamp designed to clamp through holes or slots.

Hole/Slot Size	12.5mm - 18mm
Clamping Force	578N @ 5.5BAR [130lbf @ 80PSI]
Finger Travel	15mm [0.590in] Total. Consists of: <ul style="list-style-type: none"> • 5mm [0.197in] rotational • 10mm [0.394in] straight line pull down stroke
Bore Diameter	44.5mm [1.75in]
Cylinder Stroke	15.0mm [0.59in]

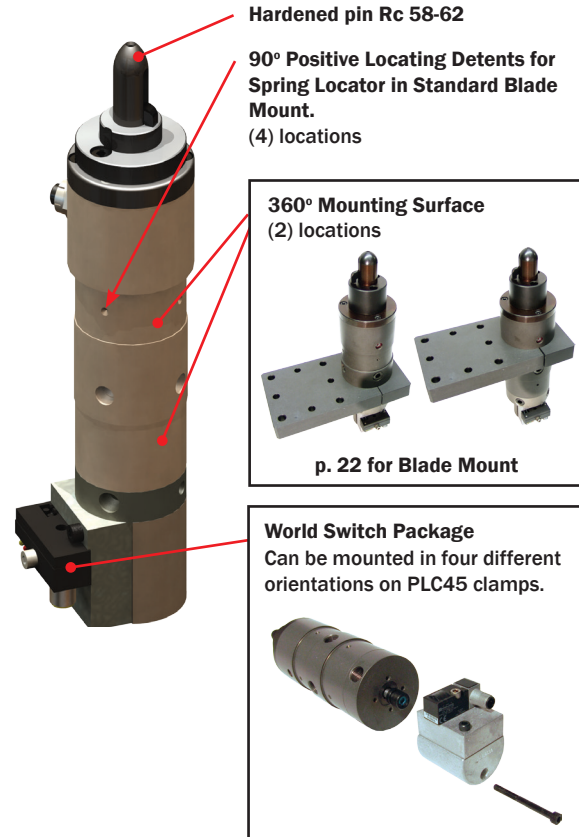

HOW TO ORDER

Call +1-810-364-4567, or email sales@btmcorp.com to request a quote!

CLAMP SELECTION		PIN SELECTION			SENSING	SPECIAL ASSEMBLY NUMBER
PLC45	N	13.00	PT	BL	PDC	XXXXXXX
CLAMP SERIES	PORT OPTION N = 1/8 NPT G = G1/8	PIN DIAMETER		PIN STYLE	PIN COATING	<p>NS (No Switch)</p> <p>PDC (Pepperl + Fuchs® DC) [Optional]</p> <p>TDC (Turck DC) [Optional]</p> <p>See p. 23</p> <p>Other switch brands are available. Contact BTM for details.</p>
		Diameter	Clamp Weight	PT = Tapered Pin	BL = Black Oxide	
		12.80	1.55kg [3.41lbs]			
		13.00	1.55kg [3.41lbs]			
		15.80	1.56kg [3.44lbs]			
16.00	1.56kg [3.44lbs]					
See p.7		<p>WE DO SPECIALS!</p> <p>BTM Pin Clamps can be ordered with custom designed (non-standard) pins, donuts, and/or fingers. In such cases, a SPECIAL ASSEMBLY number will be issued by BTM's Product Engineering Department. This number must be referenced when ordering a non-standard pin clamp.</p> <p>Example of a special "donut"</p> <p>Example of a special pin</p>				

Additional pin diameters ranging from 12.5 - 18mm are available, but are not standard. Contact BTM Company, LLC. for more information.

PLC45 PIN CLAMP

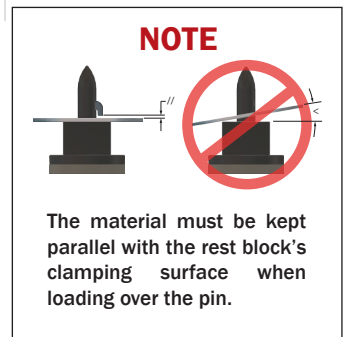
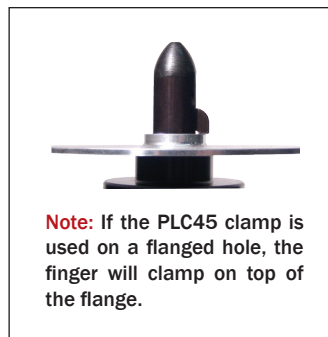
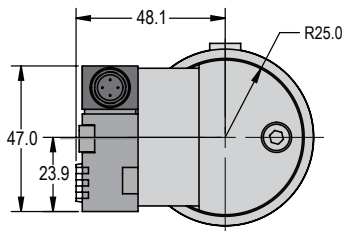
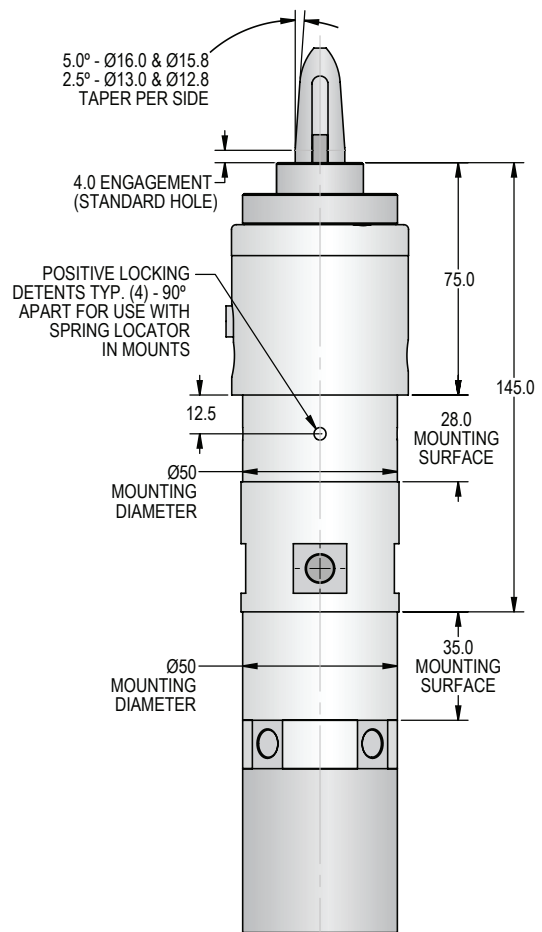
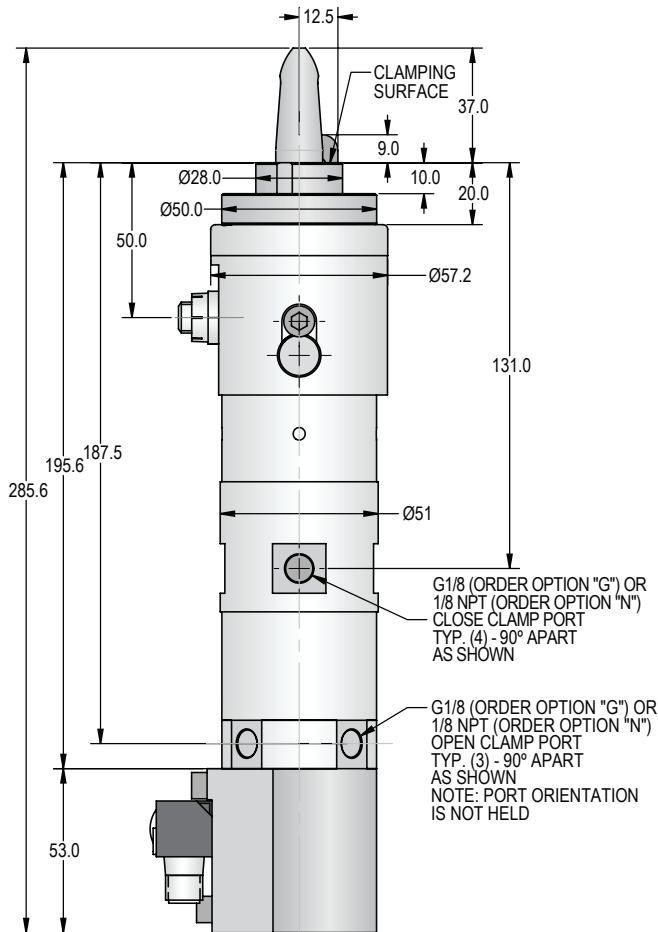

PIN DIAMETERS

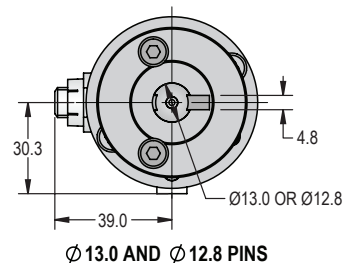
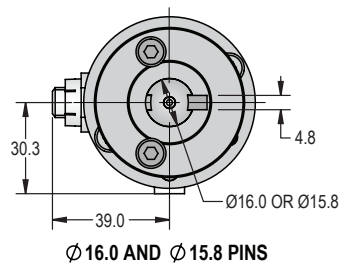

PLC63 PIN CLAMP

A non-locking pin locator clamp designed to clamp through holes or slots.

Hole/Slot Size	18mm - 40mm
Clamping Force	1334N @ 5.5BAR [300lbf @ 80PSI]
Finger Travel	15mm [0.590in] Total. Consists of: <ul style="list-style-type: none"> • 5mm [0.197in] rotational • 10mm [0.394in] straight line pull down stroke
Bore Diameter	63mm [2.50in]
Cylinder Stroke	15.0mm [0.59in]

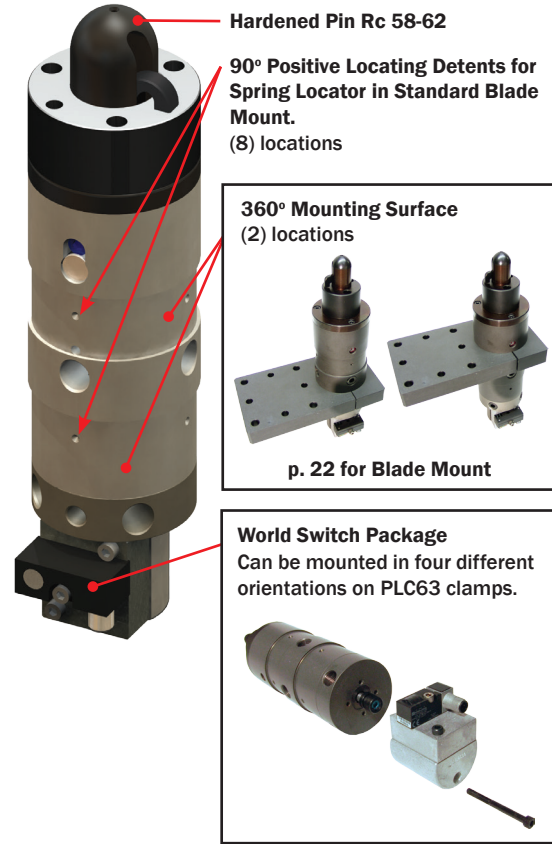

HOW TO ORDER

Call +1-810-364-4567, or email sales@btmcorp.com to request a quote!

CLAMP SELECTION		PIN SELECTION				SENSING	SPECIAL ASSEMBLY NUMBER								
PLC63	N	20.00		PT	SH	BL	PDC	XXXXXXX							
CLAMP SERIES	PORT OPTION	PIN DIAMETER			PIN STYLE	HOLE TYPE		PIN COATING	SENSING	WE DO SPECIALS!					
		Diameter	Clamp Weight	Flange Hole Option?		SH = Standard					 4.0 ENGAGEMENT	 NS (No Switch)	BTM Pin Clamps can be ordered with custom designed (non-standard) pins, donuts, and/or fingers. In such cases, a SPECIAL ASSEMBLY number will be issued by BTM's Product Engineering Department. This number must be referenced when ordering a non-standard pin clamp.		
		19.80	3.04kg [6.70lbs]	No		FL = Flanged						 10.0 ENGAGEMENT		 PDC (Pepperl + Fuchs® DC) [Optional]	
		20.00	3.04kg [6.70lbs]	No		FL only available on 25-24.8, 30-29.8, and 40-39.8mm sizes								 TDC (Turck DC) [Optional]	
		24.80	3.08kg [6.80lbs]	Yes										See p. 23 Other switch brands are available. Contact BTM for details.	
		25.00	3.08kg [6.80lbs]	Yes											
		29.80	3.86kg [8.52lbs]	Yes											
		30.00	3.86kg [8.52lbs]	Yes											
		34.80	3.92kg [8.65lbs]	No											
		35.00	3.92kg [8.65lbs]	No											
39.80	3.99kg [8.79lbs]	Yes													
40.00	3.99kg [8.79lbs]	Yes													
See p.9			Additional pin diameters are available, but are not standard. Contact BTM Company, LLC. for more information.		 Example of a special "donut"										

PLC63 PIN CLAMP

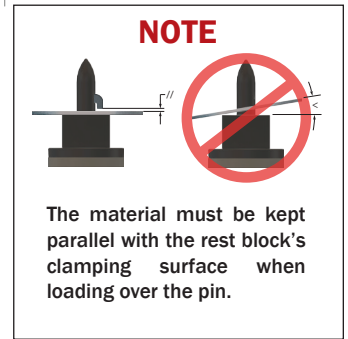
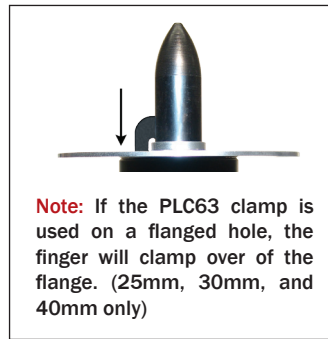
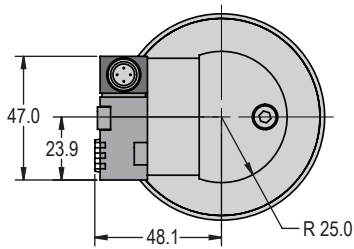
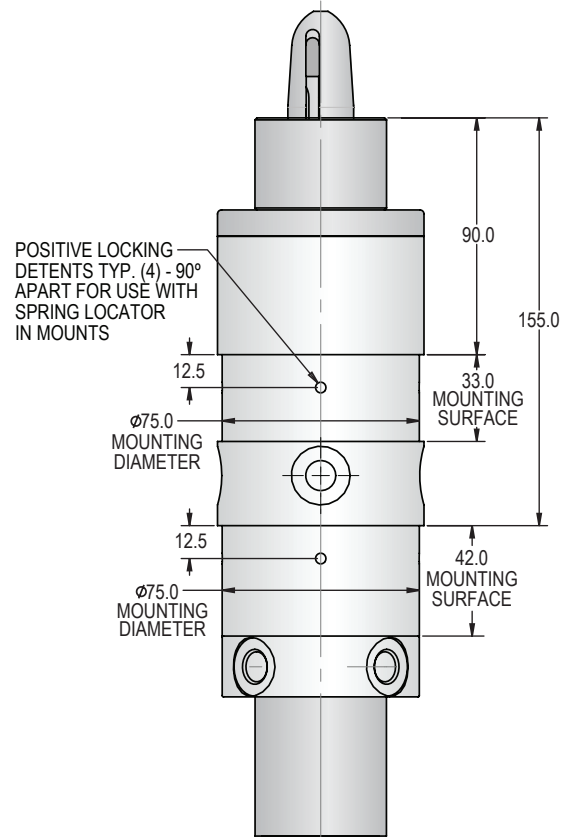
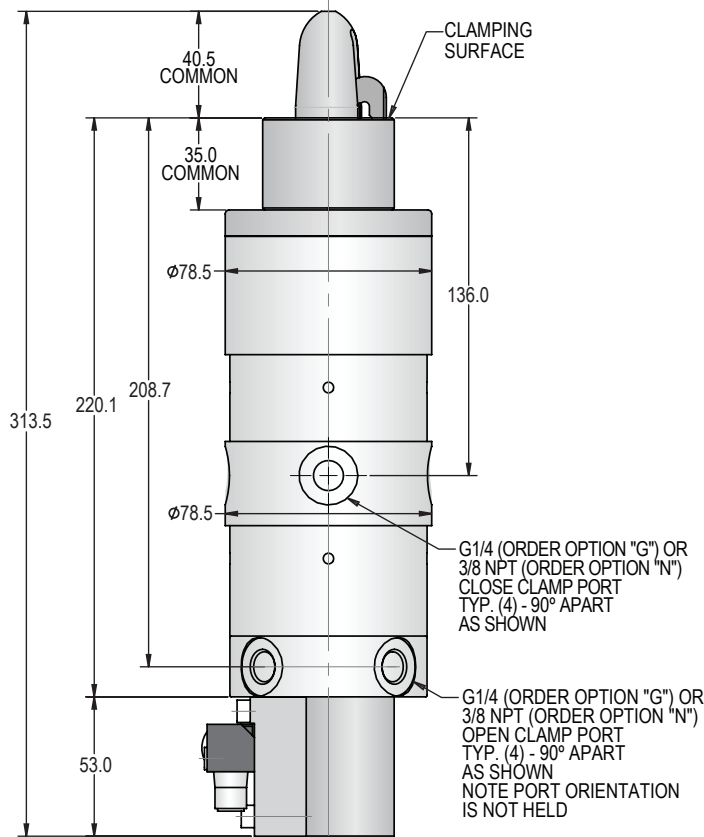

PIN DIAMETERS

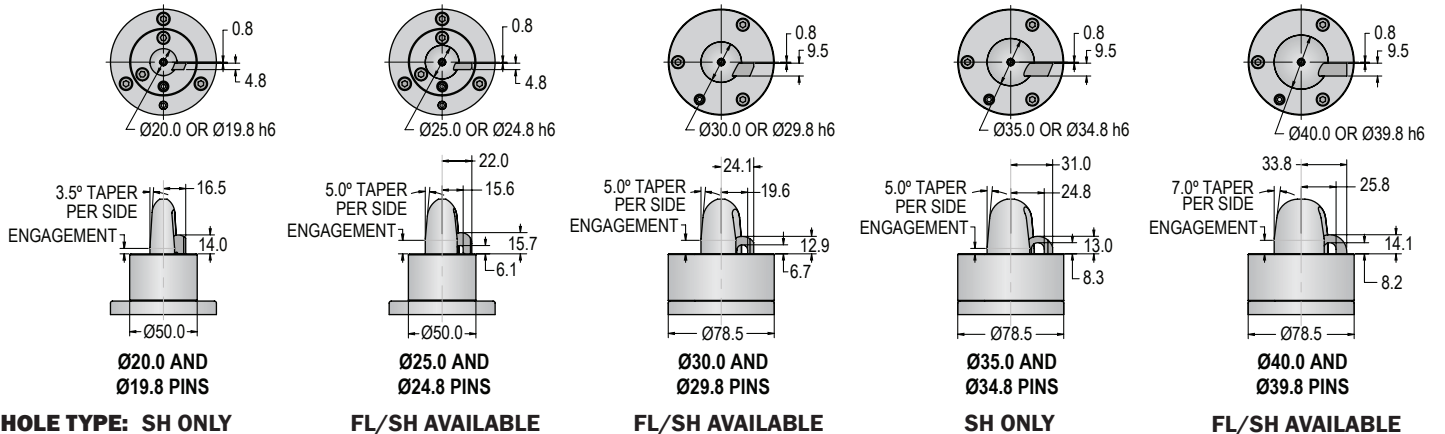

SFC63 HOOK CLAMP

A non-locking single finger clamp designed to clamp through holes or slots.

Hole/Slot Size	18mm - 40mm
Clamping Force	1334N @ 5.5BAR [300lbf @ 80PSI]
Finger Travel	15mm [0.590in] Total. Consists of: <ul style="list-style-type: none"> • 5mm [0.197in] rotational • 10mm [0.394in] straight line pull down stroke
Bore Diameter	63mm [2.50in]
Cylinder Stroke	15.0mm [0.59in]

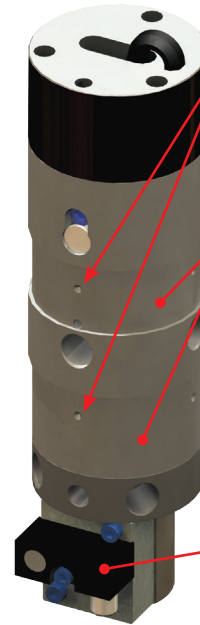

90° Positive Locating Detents for Spring Locator in Standard Blade Mount.
(8) locations



360° Mounting Surface
(2) locations

p. 22 for Blade Mount



World Switch Package
Can be mounted in four different orientations on SFC63 clamps.

MANUAL OPERATION AVAILABLE
(CONTACT BTM FOR INFORMATION)

HOW TO ORDER

Call +1-810-364-4567, or email sales@btmcorp.com to request a quote!

CLAMP SELECTION		HOLE/SLOT RANGE		SENSING		SPECIAL ASSEMBLY NUMBER		
SFC63	N	40-30		PDC		XXXXXXX		
CLAMP SERIES	PORT OPTION	Diameter	Clamp Weight		NS (No Switch)	WE DO SPECIALS! BTM Single Finger (Hook) Clamps can be ordered with custom designed (non-standard) donuts, and/or fingers. In such cases, a SPECIAL ASSEMBLY number will be issued by BTM's Product Engineering Department. This number must be referenced when ordering a non-standard single finger (hook) clamp.		
	N = 3/8 NPT	29-18	2.70kg [5.96lbs]					PDC (Pepperl + Fuchs® DC) [Optional]
	G = G1/4	40-30	3.52kg [7.77lbs]					
		See p.11		See p. 23				

Other switch brands are available.
Contact BTM for details.

SFC63 HOOK CLAMP

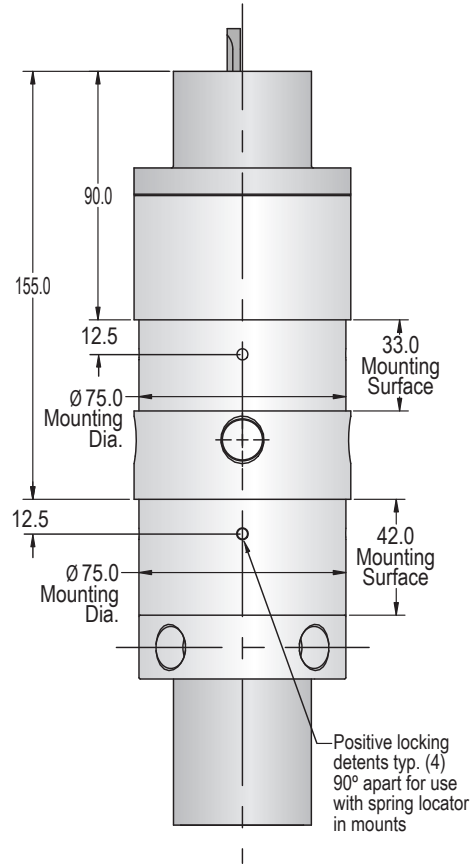
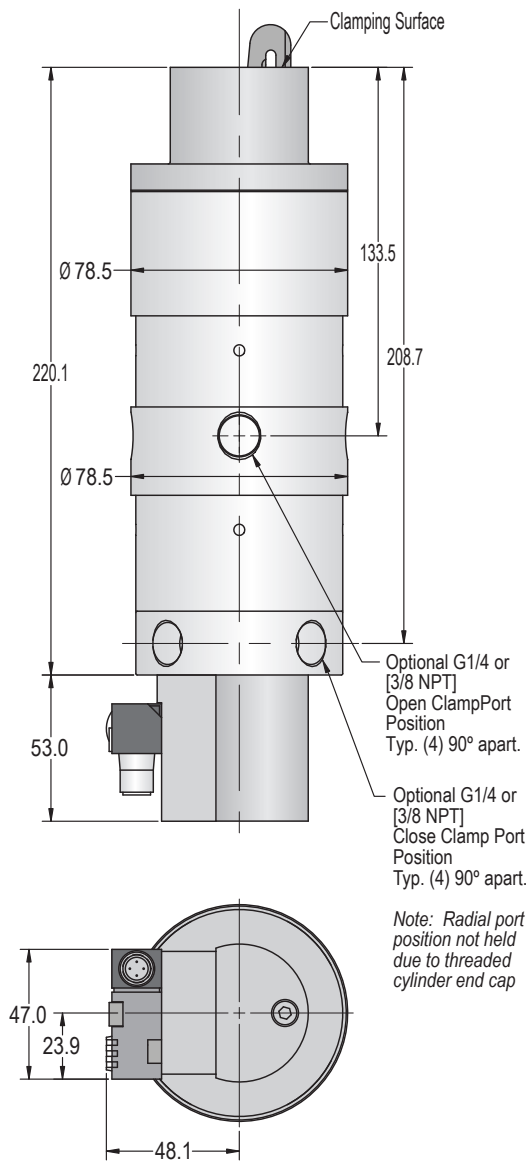

HOLE/SLOT RANGE

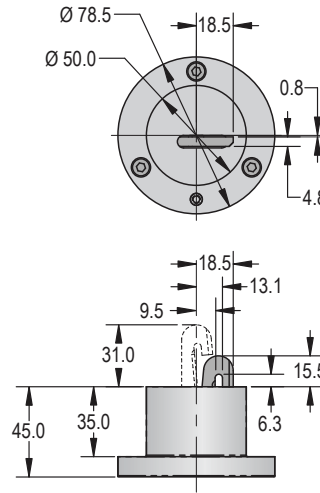

29-18 HOLE/SLOT RANGE

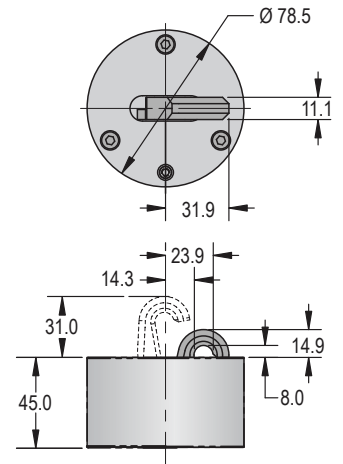

40-30 HOLE/SLOT RANGE

RLPC ROD LOCKING PIN CLAMP

RLPC clamps may be ordered with a rod locking feature, allowing the clamp to retain a part when air pressure is removed/lost. However, clamping force will not maintained. If you need to maintain clamping force after air pressure is removed/lost, please see our LPLC or LSFC.

	RLPC45	RLPC63
Hole/Slot Size	12.5mm - 18mm	18mm - 40mm
Clamping Force	578N @ 5.5BAR [130lbf @ 80PSI]	1334N @ 5.5BAR [300lbf @ 80PSI]
Finger Travel	15mm [0.590in] Total. Consists of: <ul style="list-style-type: none"> • 5mm [0.197in] rotational • 10mm [0.394in] straight line pull down stroke 	
Bore Diameter	45mm [1.77in]	63mm [2.50in]
Cylinder Stroke	15mm [0.59in]	

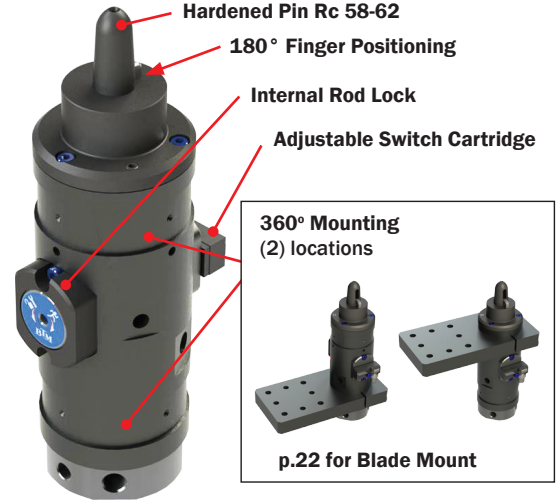

HOW TO ORDER

Call +1-810-364-4567, or email sales@btmcorp.com to request a quote!

CLAMP SELECTION			PIN SELECTION				SENSING	ROD LOCK	SPECIAL ASSEMBLY NUMBER		
RLPC	63	G	40.00				SH	F1	BDC	RL	XXXXXX
CLAMP SERIES	CLAMP SIZE	PORT OPTION	PIN DIAMETER				HOLE TYPE	FINGER POSITION	SENSING	ROD LOCK	SPECIAL ASSEMBLY NUMBER
		N = 3/8 NPT G = G1/4	Clamp Size	Diameter	Clamp Weight	Flange Hole Option?					
45 63	45	G	12.80	3.2kg [7.04lbs]	No	4.0 ENGAGEMENT	F2	BDC (Turck DC) [Optional]	RL (Rod Lock)	<p>We Do Specials!</p> <p>BTM Pin Clamps can be ordered with custom designed (non-standard) pins, donuts, and/or fingers. In such cases, a SPECIAL ASSEMBLY number will be issued by BTM's Product Engineering Department. This number must be referenced when ordering a non-standard pin clamp.</p> <p>Example of a special "donut"</p>	
			13.00	3.2kg [7.05lbs]	No						
			14.00	3.2kg [7.06lbs]	No						
			15.80	3.2kg [7.08lbs]	No						
			16.00	3.2kg [7.08lbs]	No						
			19.80	3.4kg [7.50lbs]	No						
			20.00	3.4kg [7.51lbs]	No						
			24.80	3.5kg [7.61lbs]	Yes						
	63	25.00	3.5kg [7.62lbs]	Yes	10.0 ENGAGEMENT	FL = Flanged	See p. 23	FL (Rod Lock)			
		29.80	4.0kg [8.74lbs]	Yes							
		30.00	4.0kg [8.75lbs]	Yes							
		34.80	4.0kg [8.87lbs]	No							
		35.00	4.0kg [8.88lbs]	No							
		39.80	4.1kg [9.03lbs]	Yes							
40.00	4.1kg [9.04lbs]	Yes									
			See p. 13								

If no finger position is specified, F1 will be default.

FL only available on 30-23, and 40-38mm sizes

Additional pin diameters are available, but are not standard. Contact BTM Company, LLC. for more information.

RLPC ROD LOCKING PIN CLAMP

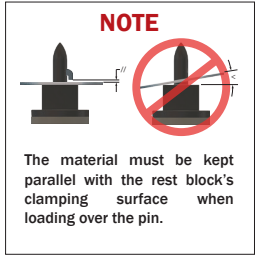
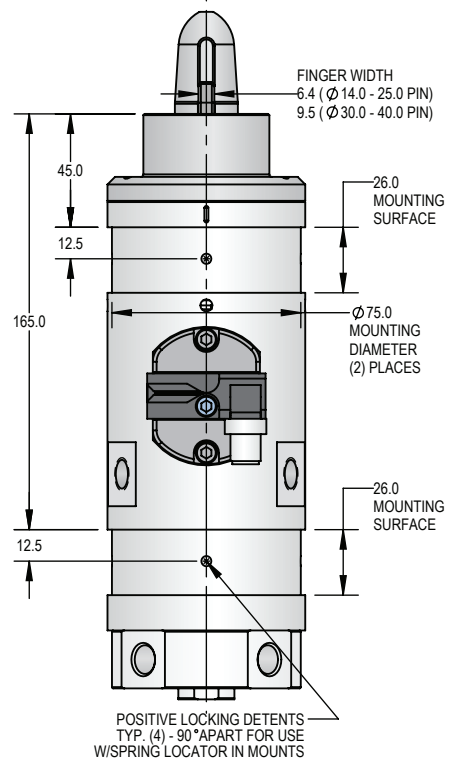
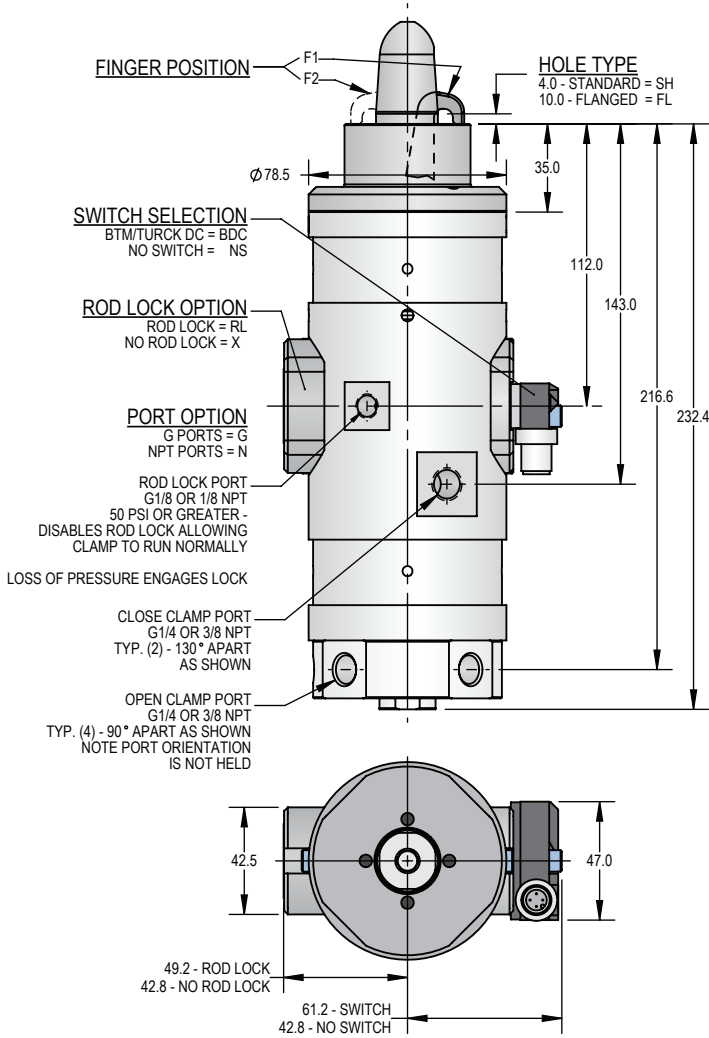

PIN DIAMETERS

RLPC45 PINS

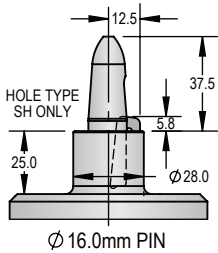
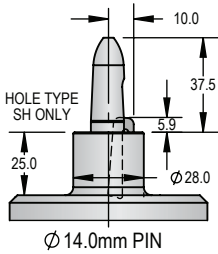

RLPC63 PINS

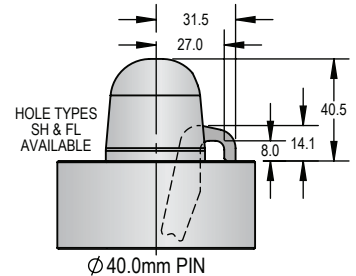
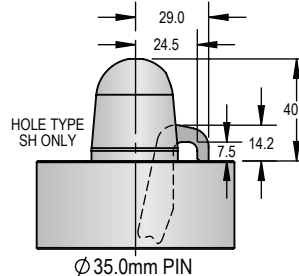
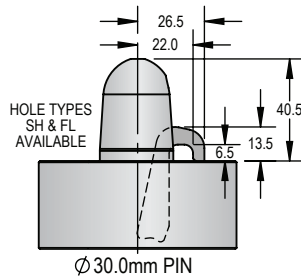
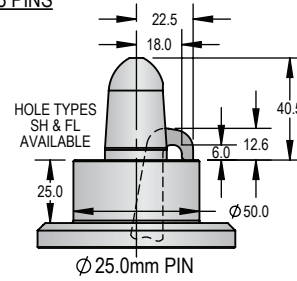
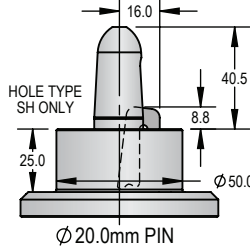

RLSFC63 ROD LOCKING HOOK CLAMP

RLSFC clamps may be ordered with a rod locking feature, allowing the clamp to retain a part when air pressure is removed/lost. However, clamping force will not maintained. If you need to maintain clamping force after air pressure is removed/lost, please see our LPLC or LSFC.

Hole/Slot Size	18mm - 40mm
Clamping Force	1334N @ 5.5BAR [300lbf @ 80PSI]
Finger Travel	15mm [0.590in] Total. Consists of: <ul style="list-style-type: none"> • 5mm [0.197in] rotational • 10mm [0.394in] straight line pull down stroke
Bore Diameter	63mm [2.50in]
Cylinder Stroke	15mm [0.59in]

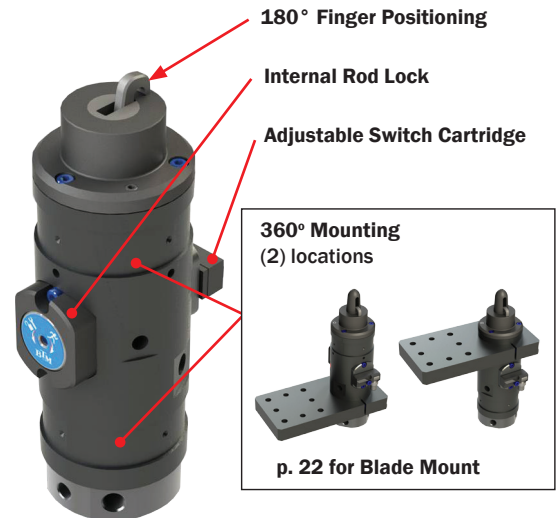

HOW TO ORDER

Call +1-810-364-4567, or email sales@btmcorp.com to request a quote!

CLAMP SELECTION			MODEL SELECTION		SENSING	ROD LOCK	SPECIAL ASSEMBLY NUMBER
RLSFC	63	G	25	F1	BDC	RL	XXXXXXX
CLAMP SERIES	CLAMP SIZE	PORT OPTION	MODEL		FINGER POSITION		WE DO SPECIALS! BTM Pin Clamps can be ordered with custom designed (non-standard) pins, donuts, and/or fingers. In such cases, a SPECIAL ASSEMBLY number will be issued by BTM's Product Engineering Department. This number must be referenced when ordering a non-standard pin clamp.
	63	N = 3/8 NPT	Hole Diameter	Clamp Weight			
		G = G1/4	25	30-23 3.4kg [7.42lbs]			
			40	40-36 3.8kg [8.46lbs]			 Example of a special "donut"
			See p. 15				

Other Sizes can be accommodated with specials. Contact BTM Company, LLC, for more information.

If no finger position is specified, F1 will be default.

See p. 23

RLSFC63 ROD LOCKING HOOK CLAMP

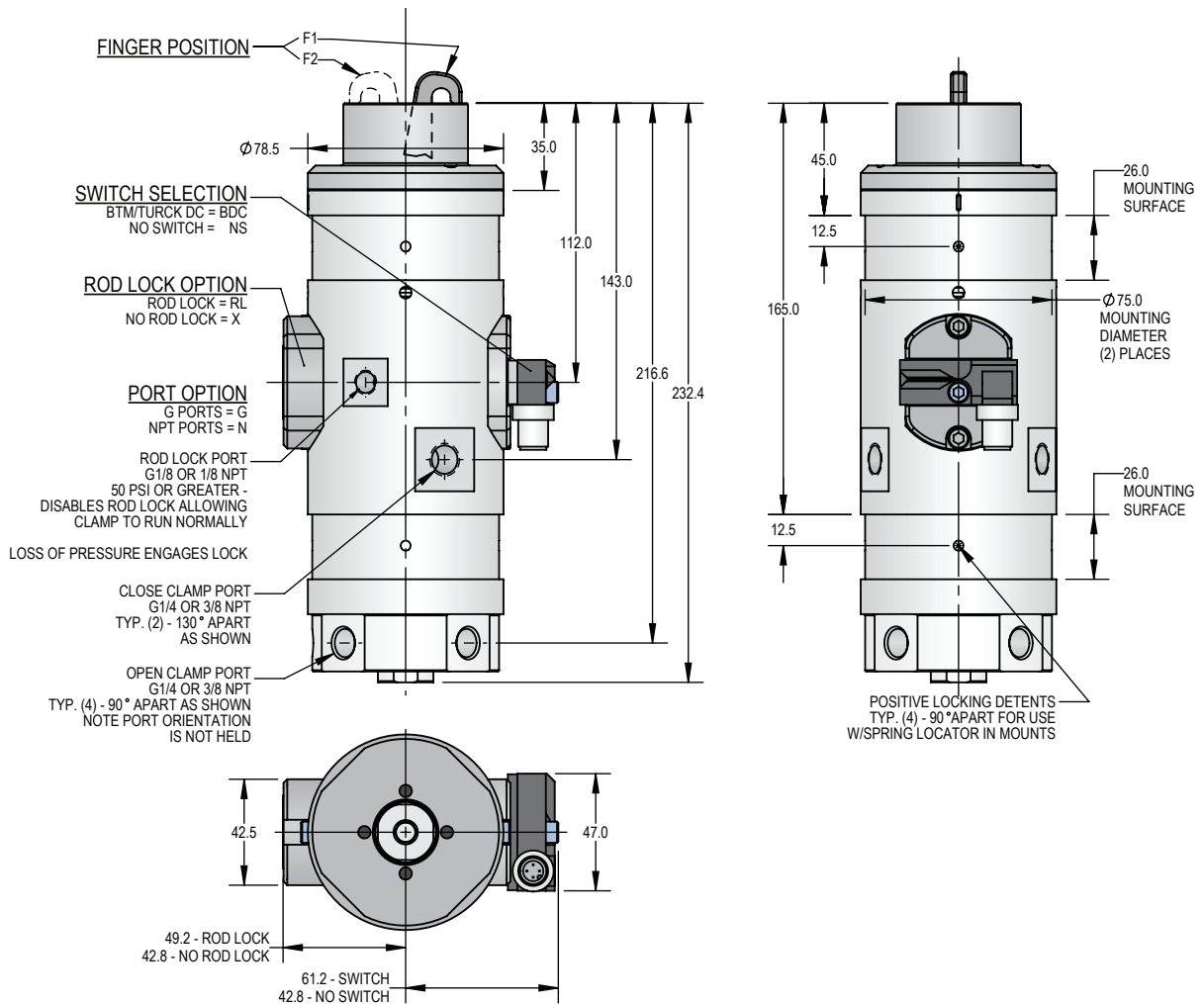

HOLE/SLOT RANGE

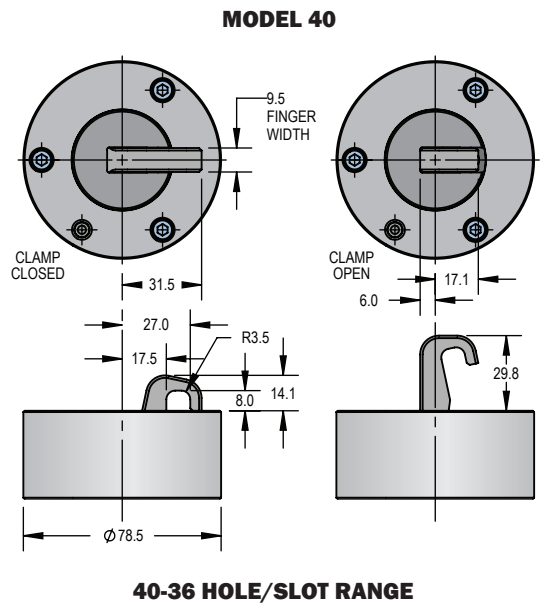
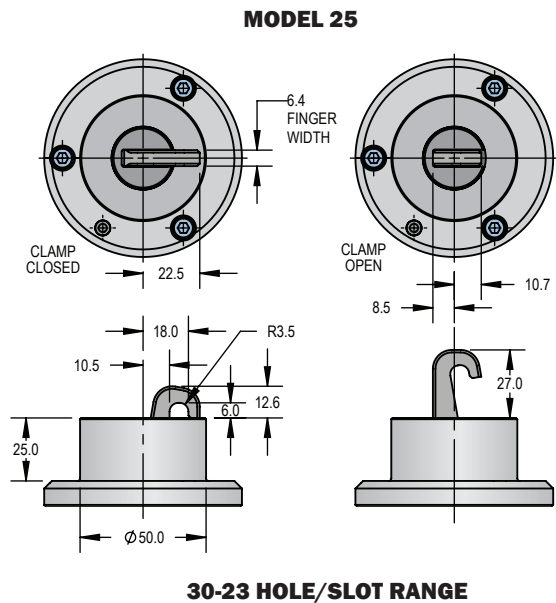

LPLC38 LOCKING PIN CLAMP



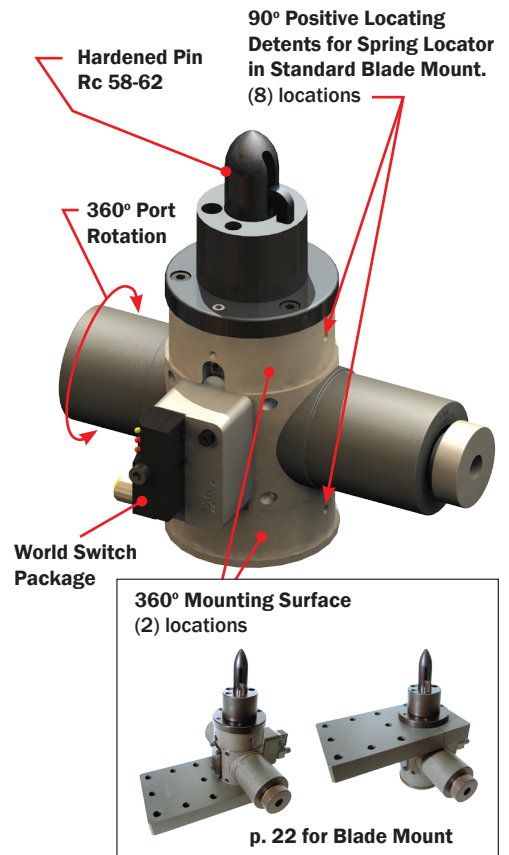

A locking pin locator clamp designed to stay locked *and* maintain clamping force even if air pressure is removed/lost.

Hole/Slot Size	18mm - 40mm
Clamping Force	890N - 1334N @ 5.5BAR [200 - 300lbf @ 80PSI]
Finger Travel	15mm [0.590in] Total. Consists of: <ul style="list-style-type: none"> • 5mm [0.197in] rotational • 10mm [0.394in] straight line pull down stroke • 3mm [0.118in] locking range (from clamping surface)
Bore Diameter	38mm [1.50in]
Cylinder Stroke	38.5mm [1.52in]

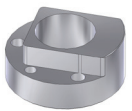

HOW TO ORDER

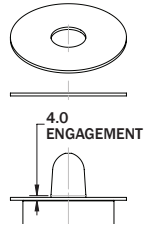
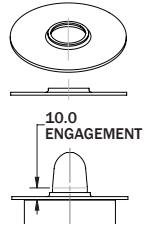
Call +1-810-364-4567, or email sales@btmcorp.com to request a quote!

CLAMP SELECTION		PIN SELECTION				SENSING		SPECIAL ASSEMBLY NUMBER								
LPLC38	N	20.00	PT	SH	BL	PDC	1	XXXXXXX								
CLAMP SERIES	PORT OPTION N = 1/8 NPT G = G1/8	PIN DIAMETER			PIN STYLE PT = Tapered Pin	HOLE TYPE		PIN COATING BL = Black Oxide	SWITCH OPTION	SWITCH POSITION	WE DO SPECIALS! BTM Pin Clamps can be ordered with custom designed (non-standard) pins, donuts, and/or fingers. In such cases, a SPECIAL ASSEMBLY number will be issued by BTM's Product Engineering Department. This number must be referenced when ordering a non-standard pin clamp.  Example of a special "donut"					
		Diameter	Clamp Weight	Flange Hole Option?		SH = Standard						NS (No Switch) 				
		19.80	3.54kg [7.81lbs]	No												
		20.00	3.54kg [7.81lbs]	No		4.0 ENGAGEMENT										
		24.80	3.59kg [7.91lbs]	Yes		FL = Flanged										
		25.00	3.59kg [7.91lbs]	Yes												
		29.80	4.33kg [9.54lbs]	Yes									10.0 ENGAGEMENT			
		30.00	4.33kg [9.54lbs]	Yes									TDC (Turck DC) [Optional] 			
		34.80	4.40kg [9.69lbs]	No											See p. 23 Other switch brands are available. Contact BTM for details.	
		35.00	4.40kg [9.69lbs]	No												
39.80	4.46kg [9.83lbs]	Yes														
40.00	4.46kg [9.83lbs]	Yes														
See p.17 for Dimension Information			FL only available on 25-24.8, 30-29.8, and 40-39.8mm sizes													

LPLC38 LOCKING PIN CLAMP

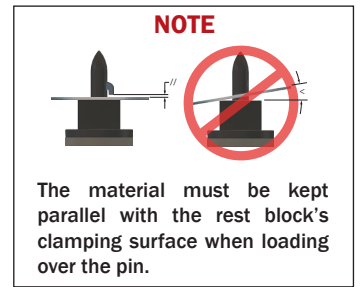
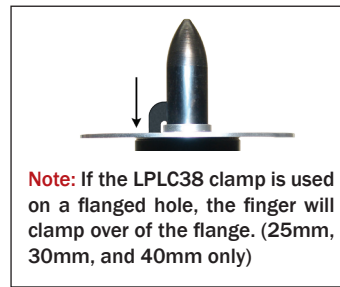
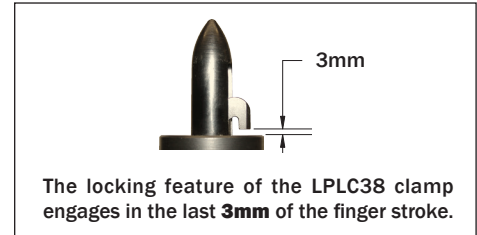
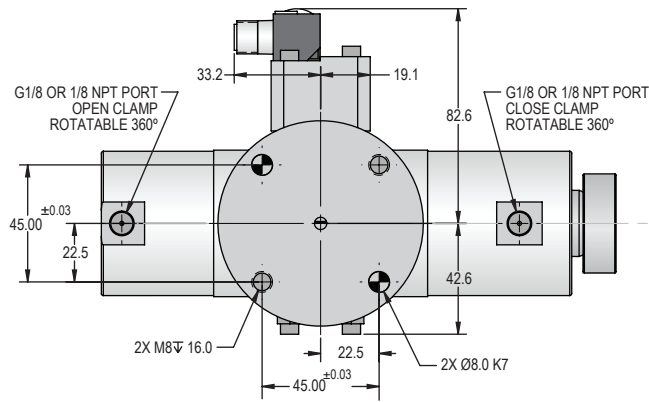
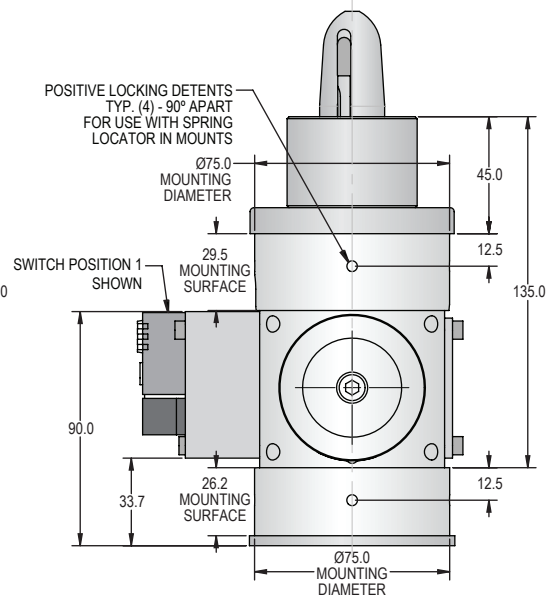
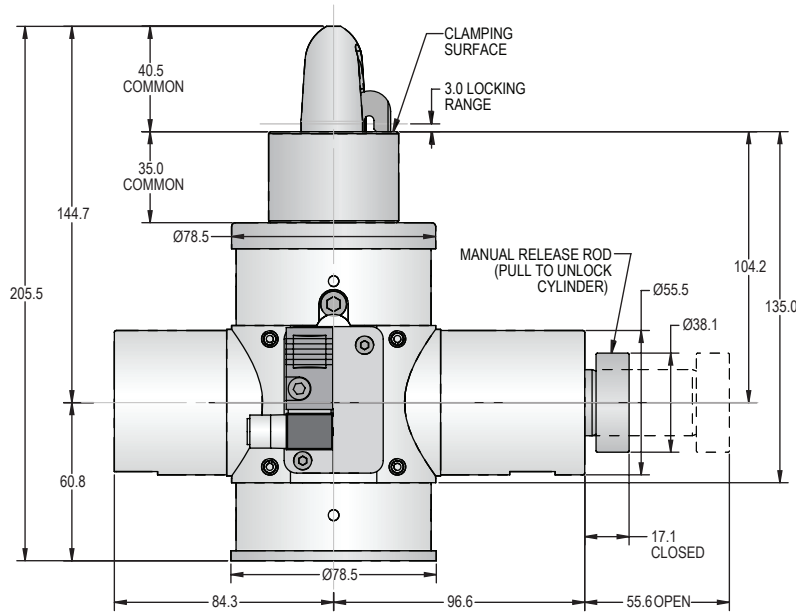

PIN DIAMETERS

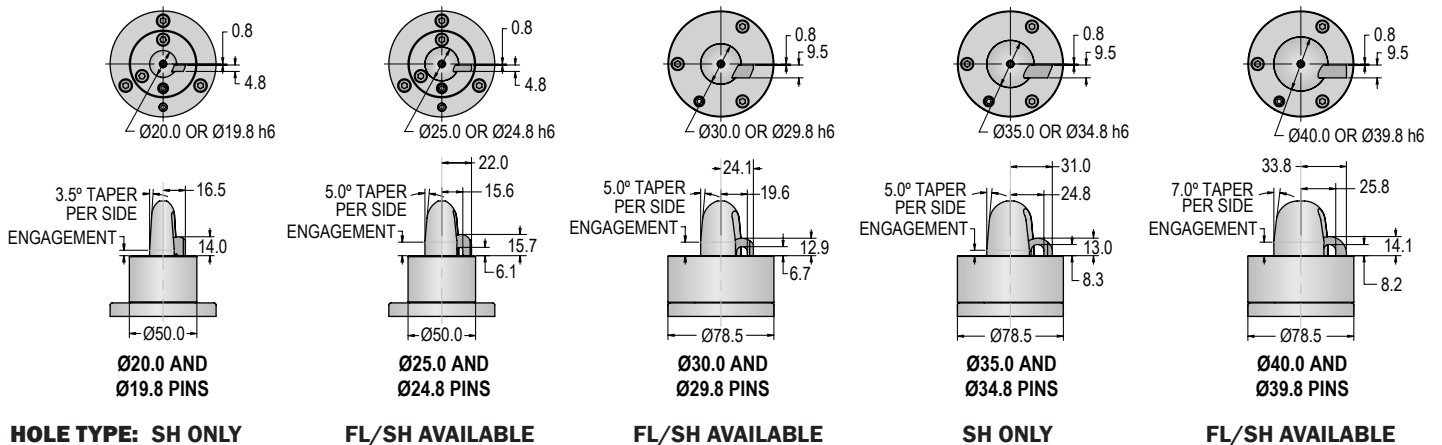

LSFC38 LOCKING HOOK CLAMP

A locking single finger clamp designed to stay locked *and* maintain clamping force even if air pressure is removed/lost.

Hole/Slot Size	18mm - 40mm
Clamping Force	890N - 1334N @ 5.5BAR [200 - 300lbf @ 80PSI]
Finger Travel	15mm [0.590in] Total. Consists of: <ul style="list-style-type: none"> • 5mm [0.197in] rotational • 10mm [0.394in] straight line pull down stroke • 3mm [0.118in] locking range (from clamping surface)
Bore Diameter	38mm [1.50in]
Cylinder Stroke	38.5mm [1.52in]

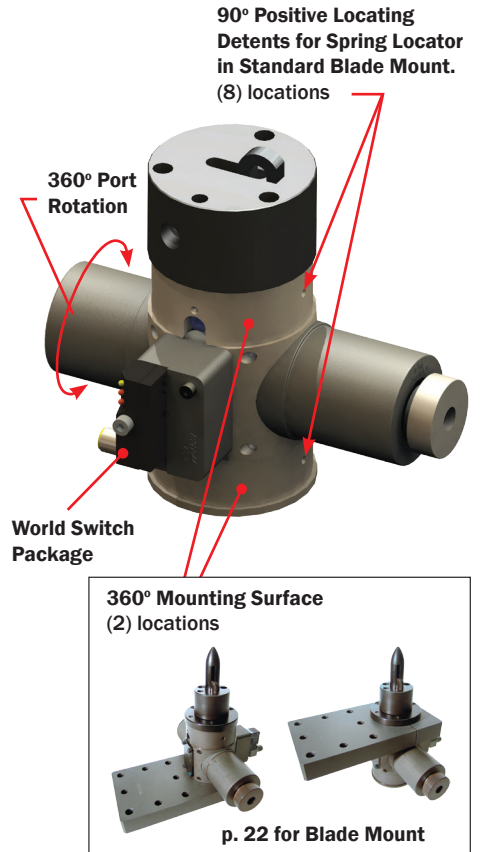

HOW TO ORDER

Call +1-810-364-4567, or email sales@btmcorp.com to request a quote!

CLAMP SELECTION		HOLE/SLOT RANGE		SENSING		SPECIAL ASSEMBLY NUMBER
LSFC38	N	40-30		PDC	1	XXXXXX
CLAMP SERIES	PORT OPTION	Diameter	Clamp Weight	SWITCH OPTION	SWITCH POSITION	WE DO SPECIALS! BTM Single Finger (Hook) Clamps can be ordered with custom designed (non-standard) donuts, and/or fingers. In such cases, a SPECIAL ASSEMBLY number will be issued by BTM's Product Engineering Department. This number must be referenced when ordering a non-standard single finger (hook) clamp. <div style="border: 1px solid black; padding: 5px; text-align: center;"> <p>Example of a special "donut"</p> </div>
	N = 1/8 NPT	29-18	3.29kg [7.25lbs]	NS (No Switch)	NS (No Switch)	
	G = G1/8	40-30	3.96kg [8.72lbs]	PDC (Pepperl + Fuchs® DC) <i>[Optional]</i>	1 (Front)	
		See p.19 for Dimension Information		TDC (Turck DC) <i>[Optional]</i>	2 (Back)	

Other switch brands are available. Contact BTM for details.

**LSFC38
LOCKING
HOOK CLAMP**

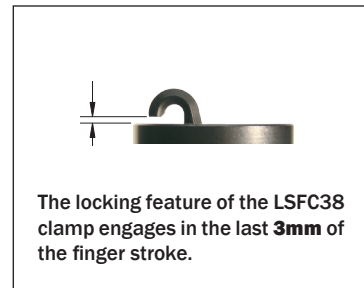
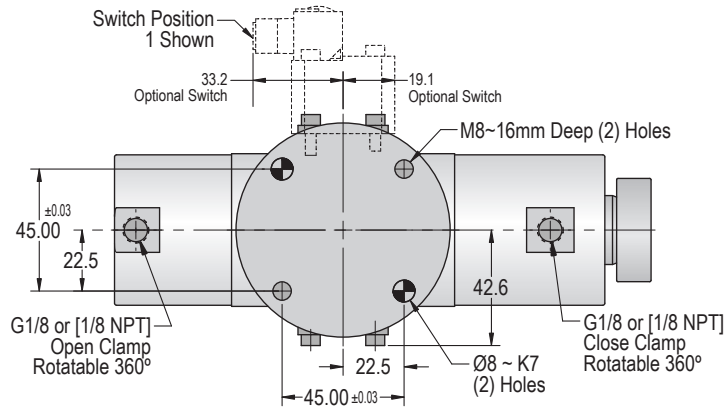
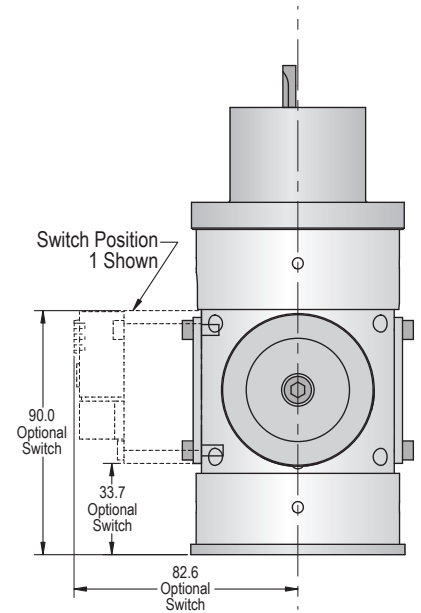
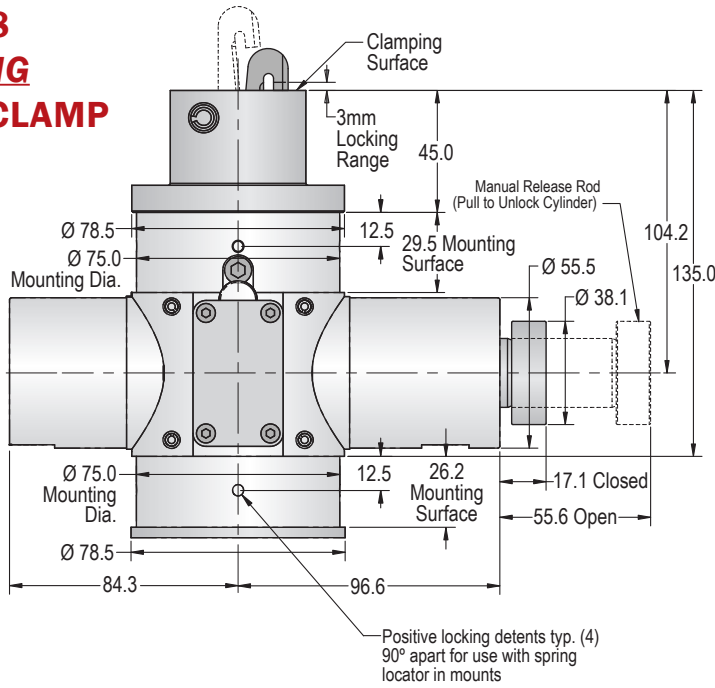

HOLE/SLOT RANGE

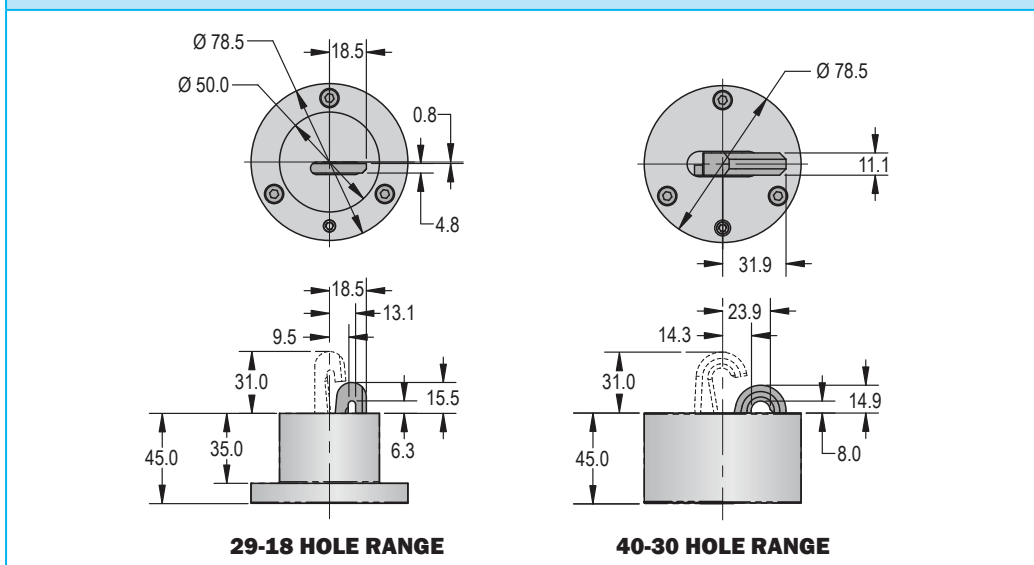

LPLC38M LOCKING MANUAL PIN CLAMP

A locking, manually operated pin locator clamp designed to maintain clamping force in the closed (locked) position.

Hole/Slot Size	18mm - 40mm
Clamping Force	1112N [250lbf]
Finger Travel	15mm [0.590in] Total. Consists of: <ul style="list-style-type: none"> • 5mm [0.197in] rotational • 10mm [0.394in] straight line pull down stroke • 3mm [0.118in] locking range (from clamping surface)

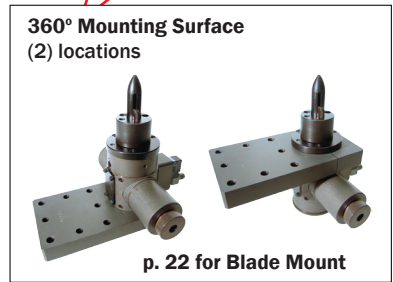
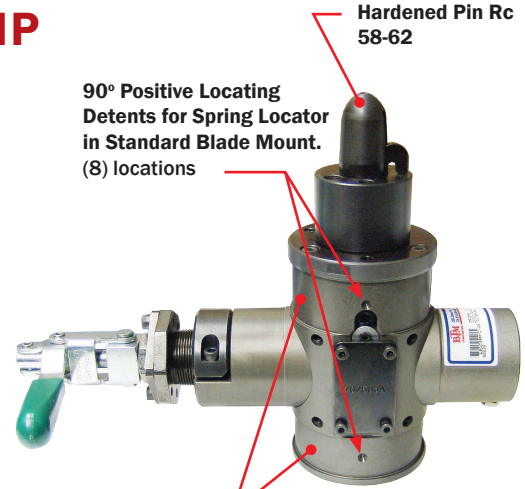

HOW TO ORDER

Call +1-810-364-4567, or email sales@btmcorp.com to request a quote!

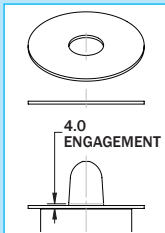
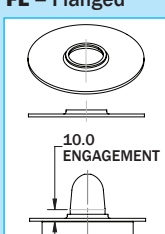
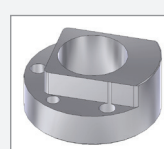
CLAMP SELECTION	HANDLE LOCATION	PIN SELECTION				SPECIAL ASSEMBLY NUMBER																								
LPLC38M	L	25.00	PT	SH	BL	XXXXXX																								
CLAMP SERIES	L = Left Side of Clamp R = Right Side of Clamp	<table border="1"> <thead> <tr> <th colspan="3">PIN DIAMETER</th> </tr> <tr> <th>Diameter</th> <th>Clamp Weight</th> <th>Flange Hole Option?</th> </tr> </thead> <tbody> <tr> <td>24.80</td> <td>3.59kg [7.91lbs]</td> <td>Yes</td> </tr> <tr> <td>25.00</td> <td>3.59kg [7.91lbs]</td> <td>Yes</td> </tr> <tr> <td>34.80</td> <td>4.40kg [9.69lbs]</td> <td>No</td> </tr> <tr> <td>35.00</td> <td>4.40kg [9.69lbs]</td> <td>No</td> </tr> <tr> <td>39.80</td> <td>4.46kg [9.83lbs]</td> <td>Yes</td> </tr> <tr> <td>40.00</td> <td>4.46kg [9.83lbs]</td> <td>Yes</td> </tr> </tbody> </table> <p>See p.21</p> <p><i>Additional pin diameters are available, but are not standard. Contact BTM Company, LLC. for more information.</i></p>	PIN DIAMETER			Diameter	Clamp Weight	Flange Hole Option?	24.80	3.59kg [7.91lbs]	Yes	25.00	3.59kg [7.91lbs]	Yes	34.80	4.40kg [9.69lbs]	No	35.00	4.40kg [9.69lbs]	No	39.80	4.46kg [9.83lbs]	Yes	40.00	4.46kg [9.83lbs]	Yes	PIN STYLE PT = Tapered Pin	HOLE TYPE SH = Standard  FL = Flanged  FL only available on 25-24.8, 30-29.8, and 40-39.8mm sizes	PIN COATING BL = Black Oxide	WE DO SPECIALS! BTM Pin Clamps can be ordered with custom designed (non-standard) pins, donuts, and/or fingers. In such cases, a SPECIAL ASSEMBLY number will be issued by BTM's Product Engineering Department. This number must be referenced when ordering a non-standard pin clamp.  <p>Example of a special "donut"</p>
PIN DIAMETER																														
Diameter	Clamp Weight	Flange Hole Option?																												
24.80	3.59kg [7.91lbs]	Yes																												
25.00	3.59kg [7.91lbs]	Yes																												
34.80	4.40kg [9.69lbs]	No																												
35.00	4.40kg [9.69lbs]	No																												
39.80	4.46kg [9.83lbs]	Yes																												
40.00	4.46kg [9.83lbs]	Yes																												

LPLC38M LOCKING MANUAL PIN CLAMP

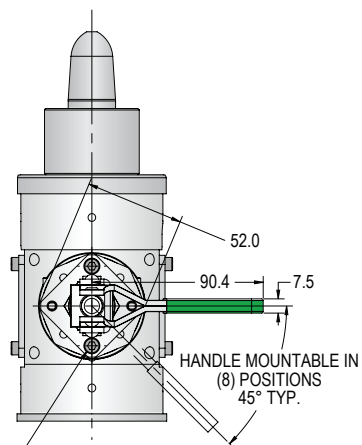
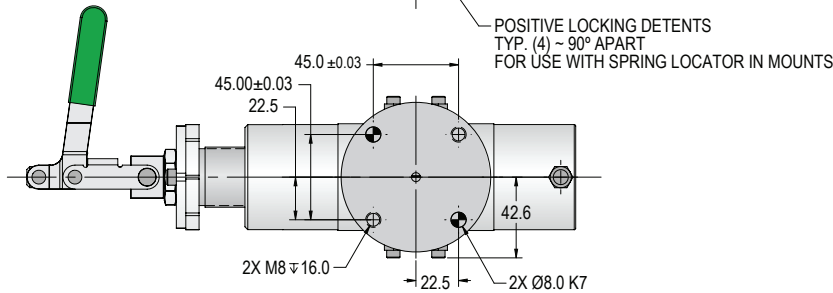
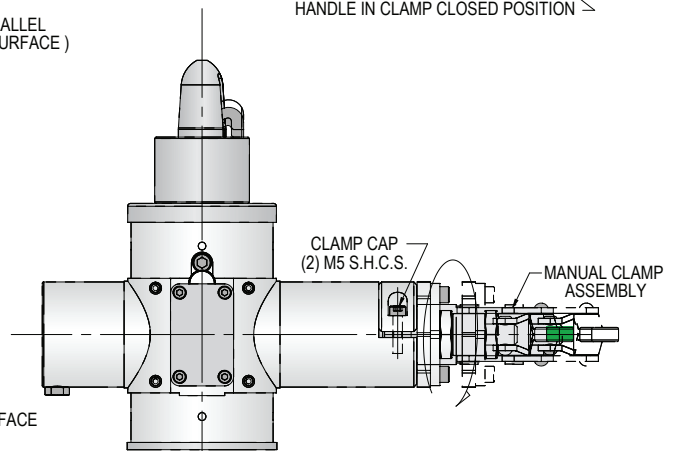
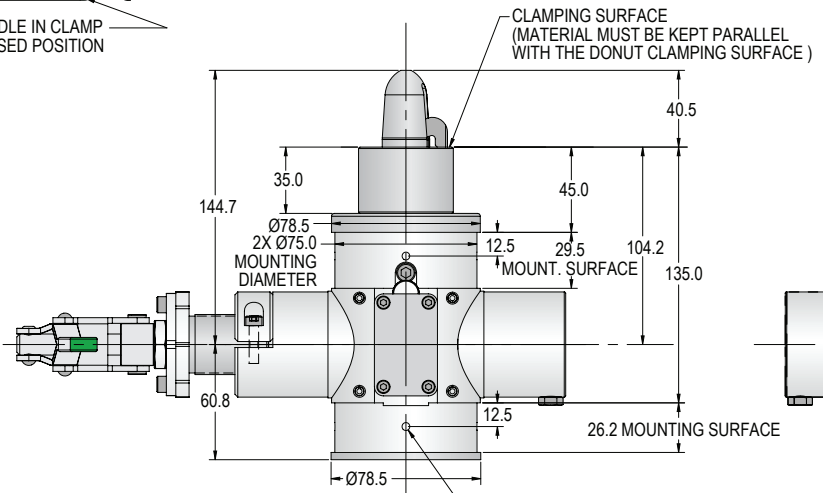
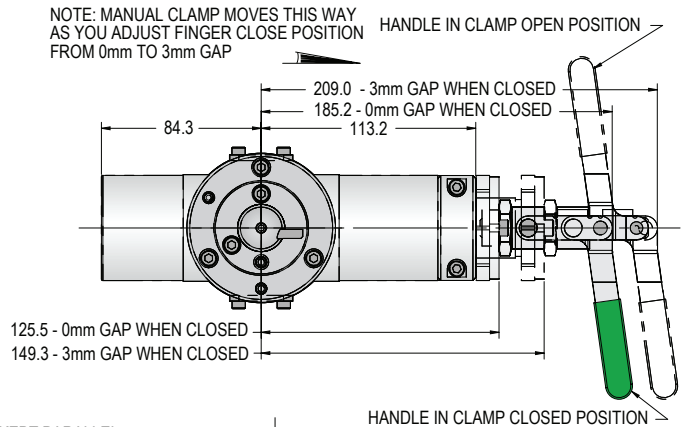
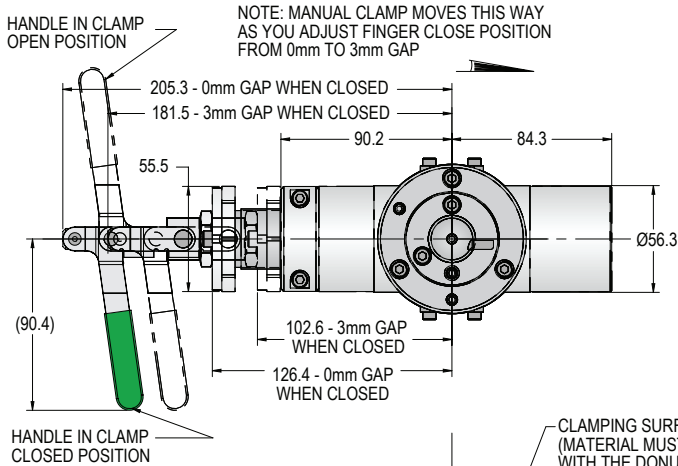

ONCE FINAL FINGER POSITION IS ESTABLISHED HANDLE MAY BE POSITIONED AS SHOWN BY REMOVING (2) M5 SHCS. WILL NOT AFFECT FINGER POSITION.

PIN DIAMETERS

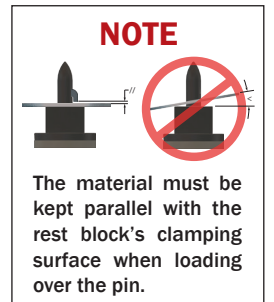
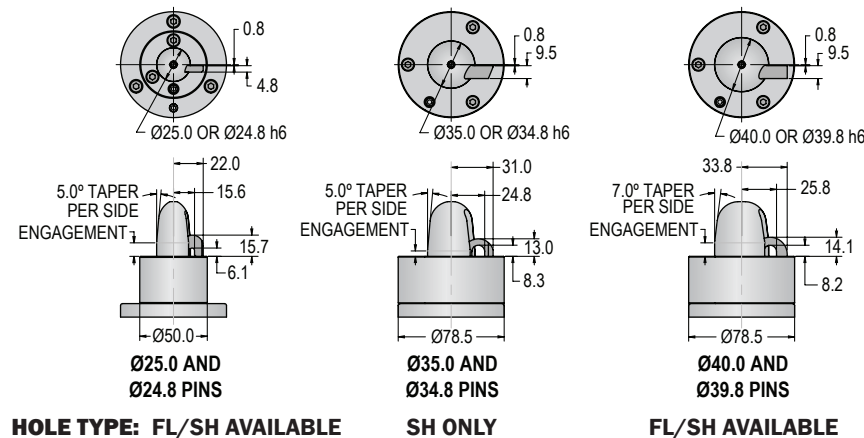

BLADE MOUNT INFORMATION

Blade style clamp mounts are currently offered in four different configurations: Insulated or non-insulated for C-flex mounting, and insulated or non-insulated for NAAMS mounting. The insulated mounts are used in welding applications, and come with insulating washers and bushings in the screw holes.

NOTE: It is the customer's responsibility to insulate any dowels required for mounting.

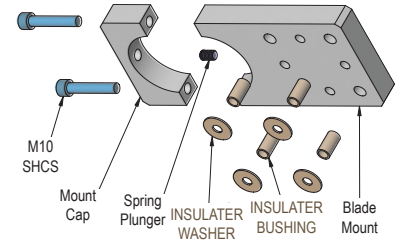

PLC45

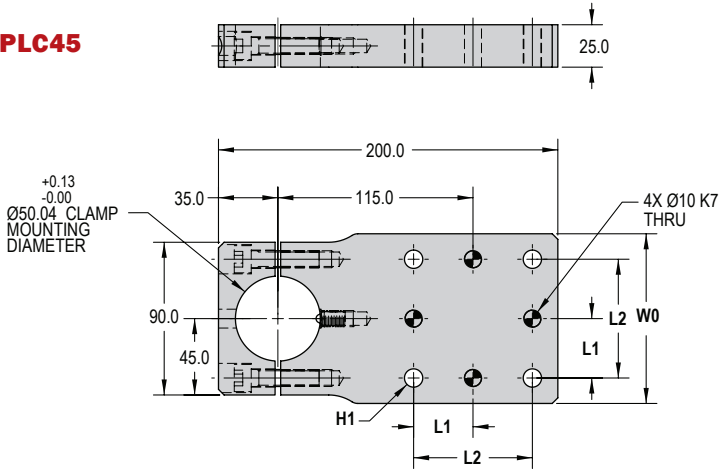

Mount Type	Ø H1 Thru (4) Holes	W0	L0	L1	L2	BTM Number
Insulated C-Flex Mount	12.0 Insulator Bushing	110.0	205.0	41.00	82.00	794400A
C-Flex Mount	12.1	110.0	205.0	41.00	82.00	794400B
Insulated NAAMS Mount	10.0 Insulator Bushing	100.0	200.0	35.00	70.00	794400C
NAAMS Mount	10.8	100.0	200.0	35.00	70.00	794400D

PLC63 SFC63 RLPC RLSFC LPLC38 LSFC38 LPLC38M

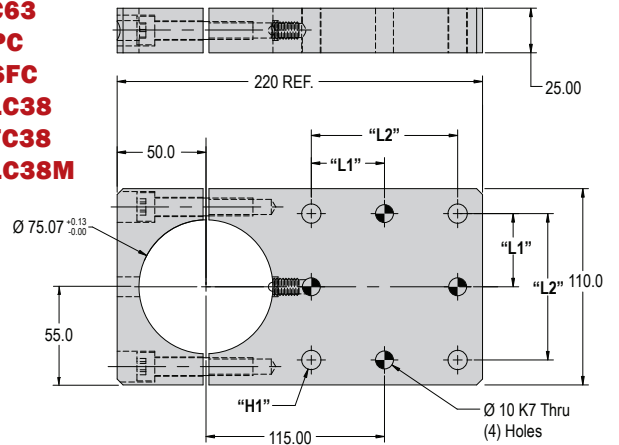

Mount Type	Ø H1 Thru (4) Holes	L1	L2	BTM Part Number
Insulated C-Flex Mount	12.0 Insulator Bushing	41.00	82.00	794100A
C-Flex Mount	12.1	41.00	82.00	794100B
Insulated NAAMS Mount	10.0 Insulator Bushing	35.00	70.00	794100C
NAAMS Mount	10.8	35.00	70.00	794100D

MOUNT PLACEMENT

PLC45, PLC63, SFC63, RLPC, RLSFC, LPLC38, and LSFC38 models have two mounting surfaces from which to apply the blade mount (upper & lower). This allows the user flexibility in choosing the placement of the clamping surface relative to the mounting surface.

PLC, RLPC, SFC & RLSFC Clamps



Lower

Upper

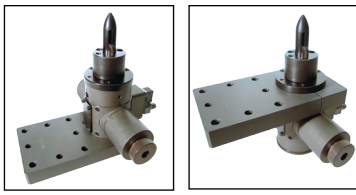

LPLC & LSFC Clamps

CLAMP ROTATION

Spring locator for positive locating of mounting reference detents.

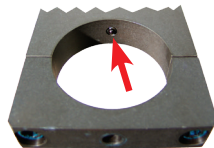

Detents are located 4 places 90° apart on round body pin clamps. Detents provided for convenience, but do not need to be used.



3-WAY SHIM MOUNT AVAILABLE

Contact BTM for more information.

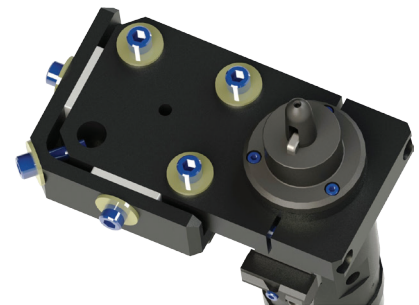

Shims X, Y, Z
± 2.5mm

SWITCH INFORMATION

STANDARD SWITCHES

FOR PLC45, PLC63, SFC63, LPLC38, & LSFC38

PDC - PEPPERL+FUCHS DC

NBN2-F581-160S6-E8-V1

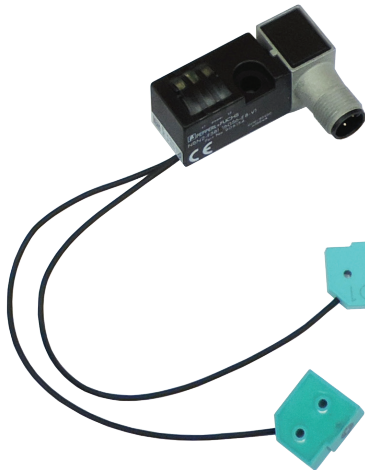

LED INDICATORS

GREEN - POWER ON
YELLOW - S1 OUTPUT ENERGIZED
RED - S2 OUTPUT ENERGIZED

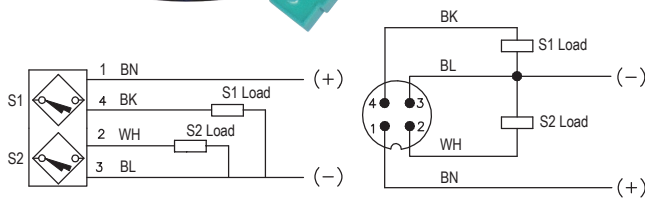

TDC - TURCK DC

Ni2Q6.5AP6-0.16-FS4.4X3/S304

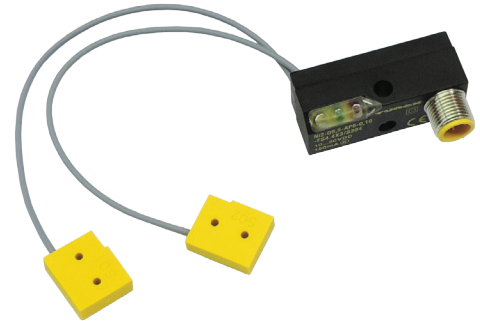

LED INDICATORS

YELLOW - S01 OUTPUT ENERGIZED
GREEN - POWER ON
RED - S02 OUTPUT ENERGIZED

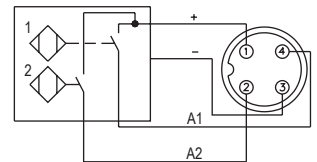

Other switches are also available (including Turck AC), but are not stocked by BTM.

STANDARD SWITCHES

FOR RLPC45, RLPC63, RLSFC63

BDC - TURCK DC

Ni2-BTM-0,16-BDS-2AP6X3-H1141/S34



LED INDICATORS

YELLOW - S01 OUTPUT ENERGIZED
GREEN - POWER ON
RED - S02 OUTPUT ENERGIZED

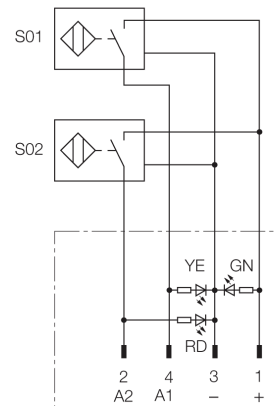



WARRANTY INFORMATION

BTM Company, LLC. warrants its Pin and Hook Clamps against defects in material and workmanship for one (1) million cycles or a period of three (3) years after the ship date from BTM, which ever comes first.

This warranty is limited to replacing or repairing at BTM's option, F.O.B. BTM's factory, any part found by BTM to be defective in materials and/or workmanship. Any application of a BTM product outside the intended use of the product shall not be warranted by BTM Company, LLC. Furthermore, BTM will not be liable for any expenses incurred for repairs or replacement made outside BTM's facilities without written consent (or damages arising out of such replacements or repairs). Under no circumstances will BTM be held responsible for any consequential damages.

The warranty is limited to the repair or replacement of the defective part(s) and does not include installation.

This warranty is the only warranty extended by the seller in connection with any sale made hereunder and is in lieu of all other warranties, express, implied or statutory including warranties of merchantability and fitness for purpose.

BTM ALSO OFFERS XPC PIN LOCATOR CLAMPS

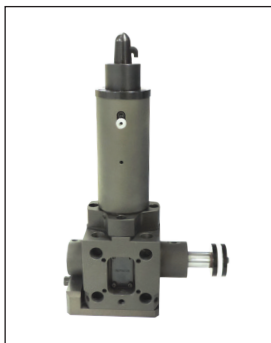

XPC Clamps are Locking Pin Locator Clamps designed with multiple extension lengths to protrude up into hard to reach locator holes while keeping the bulk of the drive cylinder away from the work area.

Model	Hole/Slot Range	Locking?	Manual Option Available?
XPC	24.8-40mm	Yes	Yes



For more information, or to view our other products, please visit:

www.BTMCOMP.COM