

MCP-5 Manual Drive Cylinder Press

Air-Over-Oil Powered Manually Assisted Short-Stroke Press

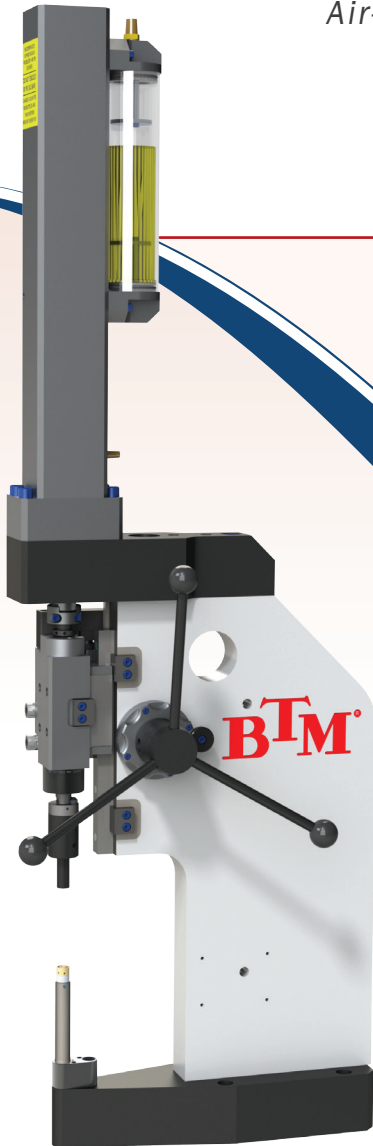

> *Ideal Press For Any Sheet Metal Fabrication Shop!*

> *Force Output of 5 Tons [45kN]!*

> *Runs on 80PSI shop air!*

www.btmcomp.com/manual-drive-cylinder-presses.html



BTM[®]
COMPANY

www.btmcomp.com

810-364-4567



SAFETY NOTE

It is the customer and/or user's responsibility to provide proper safety controls and/or guarding when a pinch point is present.

BTM's Manual Drive Cylinder Press offers you an affordable solution for your clinching, piercing, or short stroke pressing needs.

Designed with sheet metal fabrication companies in mind, this press offers an economical alternative to more traditional, and expensive bench, floor, and tooling presses.

THIS PRESS CAN BE USED WITH BTM SHEET METAL CLINCHING!

BTM Tog-L-Loc® and related clinching tools economically join sheet metal without the expense of welding or purchased fasteners by simply joining the part's own material! Assembly cost is significantly reduced by drawing and forming the part material into an interlock. Join galvanized, pre-painted, or even dissimilar metal combinations using an environmentally friendly process

that does not produce sparks, fumes or harmful heat!

By combining Tog-L-Loc clinching with this hand-assisted press, BTM delivers a high-value package which is well-suited for small to mid-size sheet metal fabricators, and manufacturing plants.

HOW A TYPICAL BTM CLINCH JOINT IS MADE:

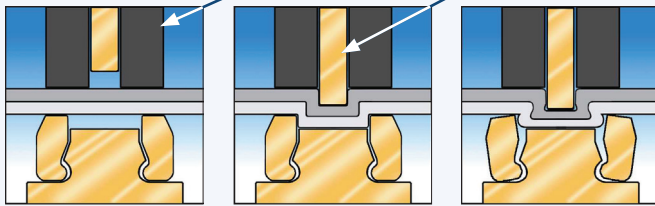

Step 1: Clamp

Step 2: Draw

Step 3: Lock

Step 1: Clamps

The **stripper** clamps the materials to be joined.

Step 2: Draws

The **punch** draws the material into the die.

Step 3: Locks

As the material flows into the die, the sides of the die expand, allowing the material to flow into an interlock.

TO LEARN MORE ABOUT BTM'S CLINCHING TECHNOLOGY, VISIT US ONLINE AT

www.btmcomp.com/clinching-solutions.html



TABLE OF CONTENTS

PRESS FEATURES **3**

PRESS DIMENSIONS **4**

OPTIONS & ACCESSORIES **5**

HOW-TO-ORDER **6**

CLINCH TOOLING REFERENCE **7**

! BTM reserves the right to make changes to its literature without any prior notice. Go to www.btmcomp.com for latest version.

PRESS FEATURES

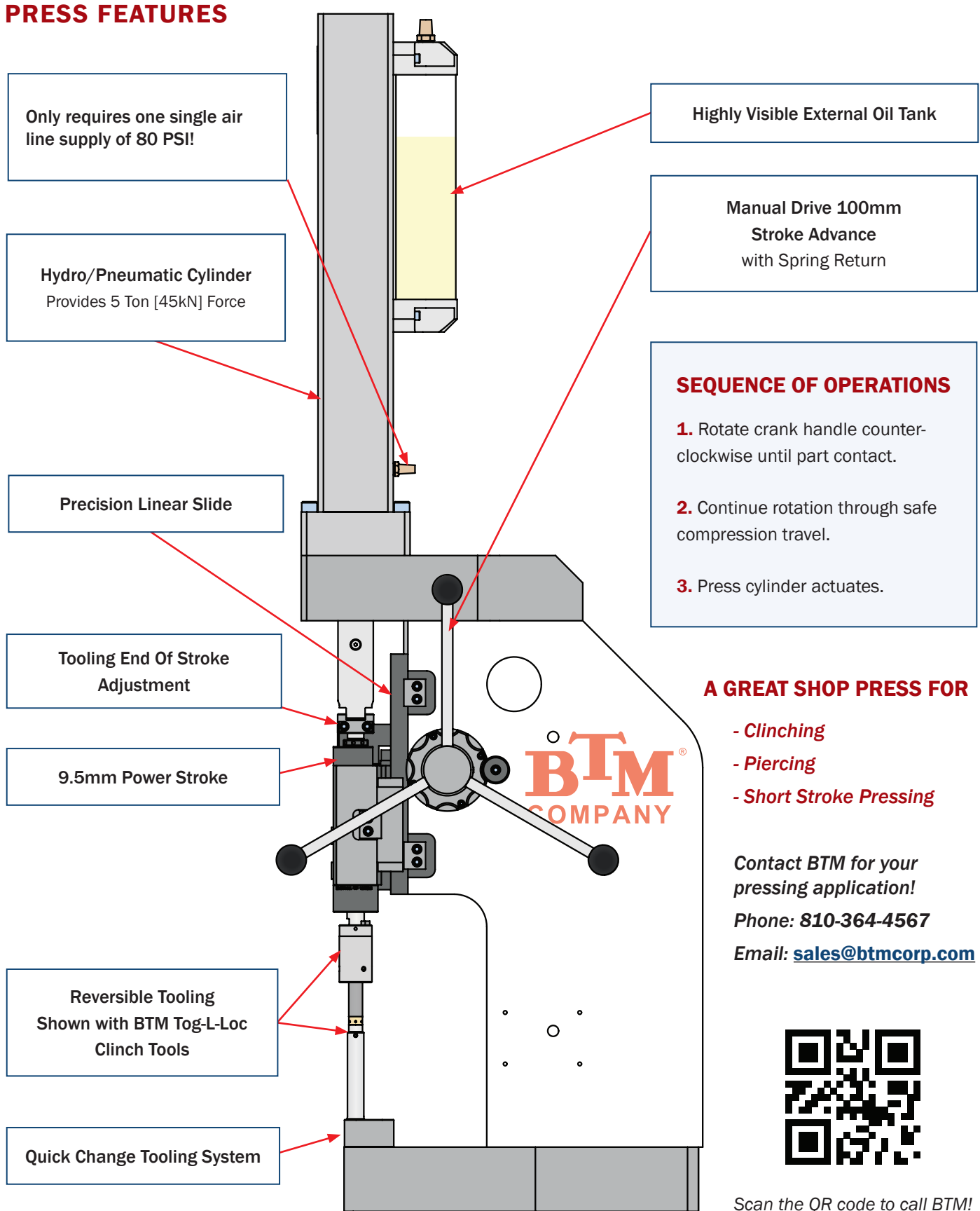

Only requires one single air line supply of 80 PSI!

Hydro/Pneumatic Cylinder Provides 5 Ton [45kN] Force

Precision Linear Slide

Tooling End Of Stroke Adjustment

9.5mm Power Stroke

Reversible Tooling Shown with BTM Tog-L-Loc Clinch Tools

Quick Change Tooling System

Highly Visible External Oil Tank

Manual Drive 100mm Stroke Advance with Spring Return

SEQUENCE OF OPERATIONS

1. Rotate crank handle counter-clockwise until part contact.
2. Continue rotation through safe compression travel.
3. Press cylinder actuates.

A GREAT SHOP PRESS FOR

- Clinching
- Piercing
- Short Stroke Pressing

Contact BTM for your pressing application!
 Phone: 810-364-4567
 Email: sales@btmcorp.com

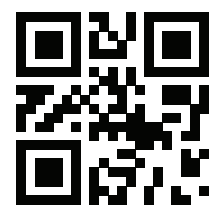

Scan the QR code to call BTM!

PRESS DIMENSIONS

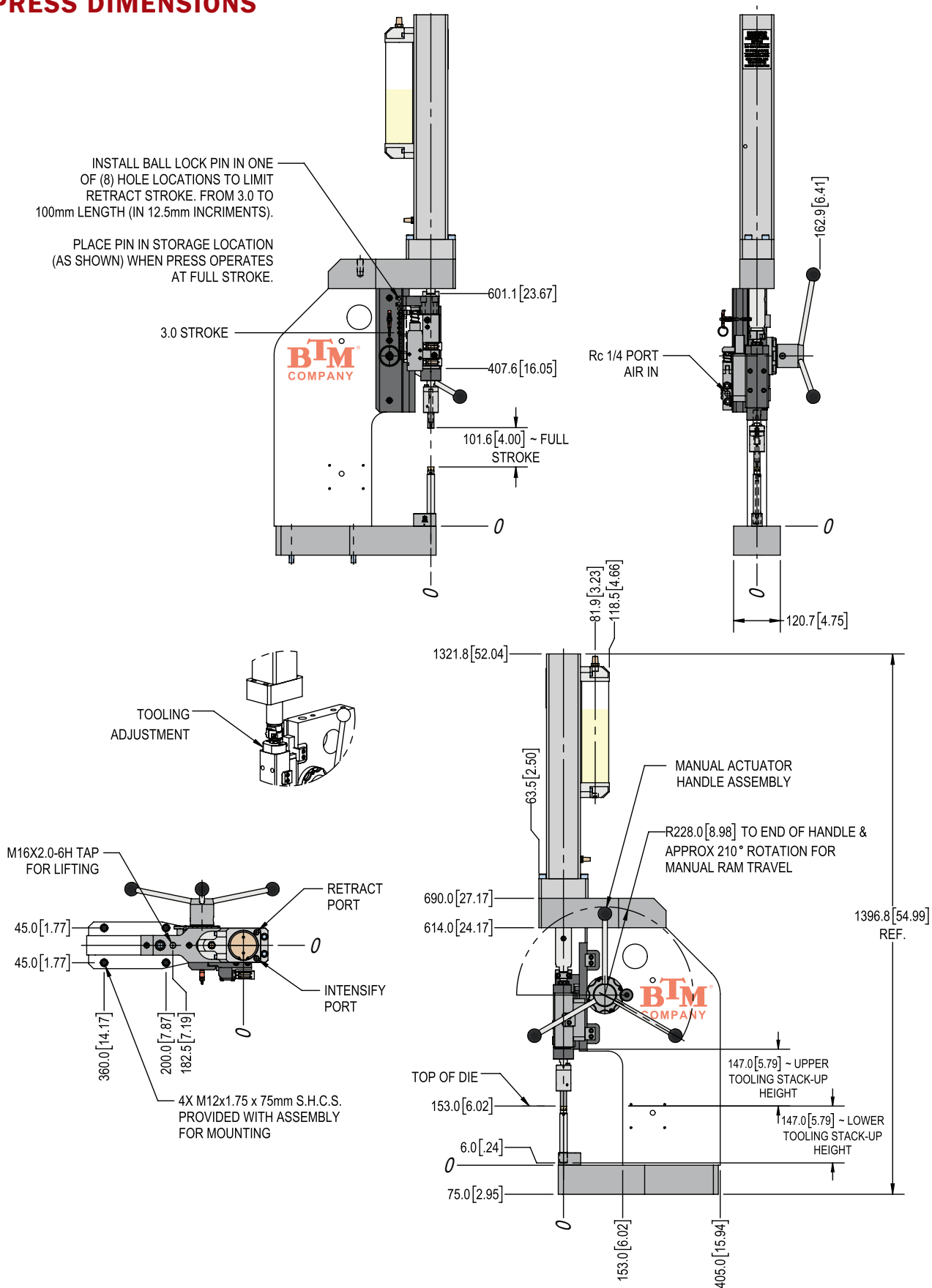

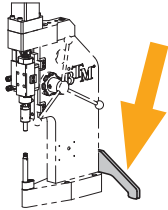
PRESS OPTIONS & ACCESSORIES**OPTIONAL MOUNTING****BENCH LEG***(BTM No. PD307211A)*

Convert your press into a bench-top unit with this support leg.

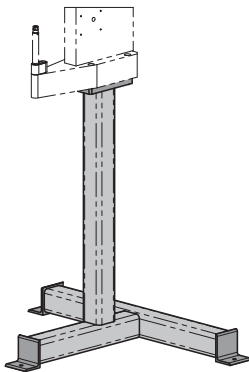
USE ORDER CODE:**BL****RISER BASE***(BTM No. PD307212A)*

The Riser Base effectively converts your press into a floor press.

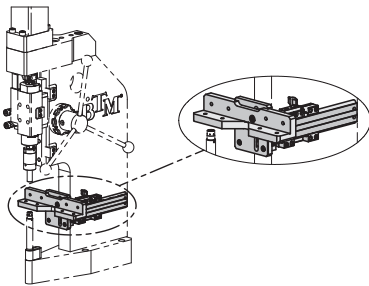
USE ORDER CODE:**RB****OPTIONAL NESTING / LOCATING****ADJUSTABLE FENCE ASSEMBLY***(BTM No. PD307200F)*

This Adjustable Fence Assembly helps you to nest/locate the parts being joined.

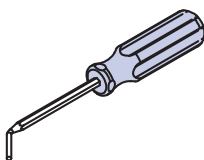
USE ORDER CODE:**FA****HARDWARE****BALL RELEASE TOOL***(BTM No. 044514)*

This tool allows you to release ball-lock retention.

USE ORDER CODE:**BRT**

HOW TO ORDER

Ordering your new Hand-Assisted Clinching Press is easy! Just follow the 3 steps below!

STEP 1

BEFORE YOU PLACE AN ORDER - Please contact BTM to determine the correct tooling for your application. To contact us, please email us at sales@btmcorp.com or call us at **810-364-4567!**



STEP 2

Fill in the blanks below. You must specify at least the **PRESS AND TOOLING** sections as a minimum order. **OPTIONS** are a great way to add value to your press, but are not required.

PRESS	TOOLING (REQUIRED)	OPTIONS (LEAVE BLANK IF NOT DESIRED)								
PD307200A	-		-		-		-			
MCP-5 PRESS ASSEMBLY		Punch Holder <small>Based on application</small>		Die Assembly <small>Based on application</small>		Mounting BL = Bench Leg RB = Riser Base <small>See p.5</small>		Nesting/Locating FA = Adjustable Fence <small>See p.5</small>		Hardware BRT = Ball Release Tool <small>See p.5</small>
		Contact BTM		Contact BTM						

EXAMPLE

PRESS	TOOLING	OPTIONS								
PD307200A	-	PD263900G	-	716000GE	-	BL	-	FA	-	BRT



STEP 3

Email your order to sales@btmcorp.com, call us at **810-364-4567**, or fax a copy of this page to 810-364-6178. Please fill out the blanks below if faxing or emailing this page & a BTM Sales Representative will contact you to complete your order.

Your Name _____

Company _____

Phone _____

Email _____

CLINCH TOOLING REFERENCE

PD308500A ~ TL-BL-PH20 HOLDER ASSY
(INCLUDED WITH PD307200A MCP-5)

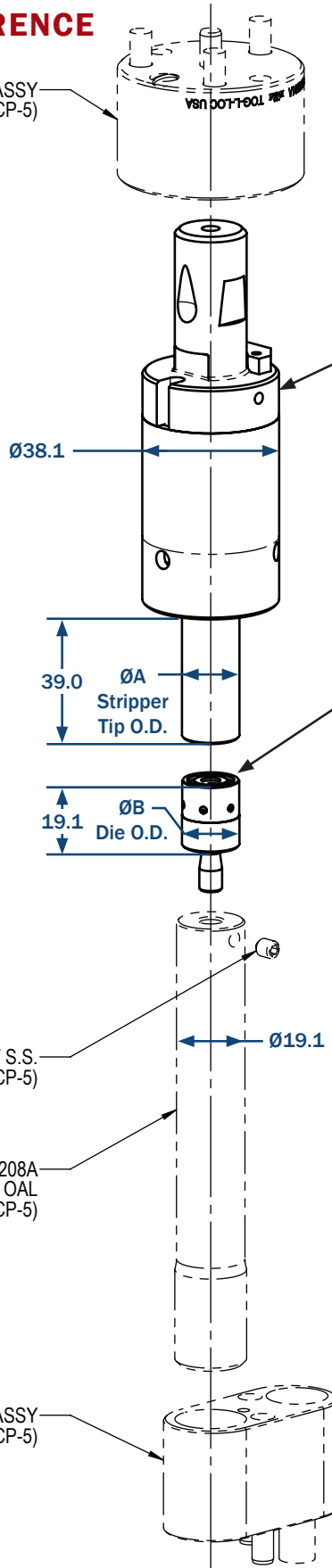

025972 ~ M5x0.8 x 6mm CUP PT S.S.
(INCLUDED WITH PD307200A MCP-5)

PD307208A
MCP-5 TL-940-BL20-DHA DIE HOLDER_147 OAL
(INCLUDED WITH PD307200A MCP-5)

737400L ~ PP-BL-MPH20 HOLDER ASSY
(INCLUDED WITH PD307200A MCP-5)

BEFORE YOU ORDER TOOLING

Contact BTM to determine the correct clinch tooling for your application.

Email us at sales@btmcorp.com or call us at 810-364-4567!

TOG-L-LOC SS20 PUNCH HOLDER ASSEMBLY

JOINT SIZE	ØA	PUNCH TIP RADIUS	PUNCH HOLDER ASSEMBLY NO.
3.0 Tog-L-Loc (TL-3.0)	Ø12	0.25 [0.010]	PD264000G
		0.51 [0.020]	PD264000H
3.8 Tog-L-Loc (TL-3.8)	Ø14	0.25 [0.010]	PD264100G
		0.51 [0.020]	PD264100H
4.6 Tog-L-Loc (TL-4.6)	Ø16	0.25 [0.010]	PD263900G
		0.51 [0.020]	PD263900H

TOG-L-LOC 940 STYLE "A" DIE ASSEMBLY

JOINT SIZE	ØB	ANVIL DEPTH	DIE ASSEMBLY NO.
3.0 Tog-L-Loc (TL-3.0)	Ø12	0.51 [0.020]	718200BE
		0.64 [0.025]	718200CE
		0.76 [0.030]	718200DE
		0.89 [0.035]	718200EE
		1.02 [0.040]	718200FE
		1.14 [0.045]	718200GE
3.8 Tog-L-Loc (TL-3.8)	Ø13.5	0.51 [0.020]	794600BE
		0.64 [0.025]	794600CE
		0.76 [0.030]	794600DE
		0.89 [0.035]	794600EE
		1.02 [0.040]	794600FE
		1.14 [0.045]	794600GE
4.6 Tog-L-Loc (TL-4.6)	Ø16.0	0.51 [0.020]	716000BE
		0.64 [0.025]	716000CE
		0.76 [0.030]	716000DE
		0.89 [0.035]	716000EE
		1.02 [0.040]	716000FE
		1.14 [0.045]	716000GE
		1.27 [0.050]	716000HE
		1.40 [0.055]	716000JE
		1.52 [0.060]	716000KE
		1.65 [0.065]	716000LE
1.78 [0.070]	716000ME		



OTHER PRODUCTS FOR AUTOMATION

Clamps



From heavy duty precision sealed locking power clamps to simple light duty OMNI models, BTM manufactures clamps in a range of styles and sizes for a wide variety of applications.

Grippers



BTM manufactures a high quality line of grippers ranging from heavy duty models to light duty models in a variety of styles and sizes.

OTHER QUALITY BTM PRODUCTS TO CONSIDER

Pin Locator Clamps



BTM's Locator Clamps are ideal for locating & holding production material and are used in a variety of manufacturing areas including automotive & refrigeration.

Pin Sizes range from as small as 6mm (PLC-25 Light Duty Clamp) to as large as 40mm (PLC-63 & LPLC-38 locking clamp).

Single Finger Hook Models (without the locating pin) are also available in both locking and non-locking configurations.

Rod-Locking Pin Locator Clamps



These clamps employ a rod locking feature which allows the clamp to retain the part when air pressure is removed/lost.

Precision Shot Pin Cylinders

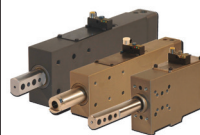

BTM's Precision Shot Pin Cylinders are ideal for locating production material through precisely pierced holes - including clamping and fixturing.

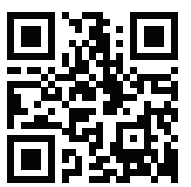

For more information, or to view our other products, please visit:

www.BTMCOMP.COM